

MODEL: **Delabie DLB-40000**

DELABIE

Compact manual mixer

FEATURES & BENEFITS

- For individual washbasins, to be installed underneath the washbasin.
- 1/2-inch BSP(MF) with non-return valves and filters.
- Nickel body.
- Integrated stopcocks (function can be easily checked) and filters.
- Water supplies to mixer valves - operating pressures to be between 1 and 5 bar.

MAINTENANCE & CLEANING

Cleaning chrome: Do not use abrasive, chlorine or acid-based cleaning products. Avoid contact with concentrated bleach. Clean with soapy water using a cloth or sponge.

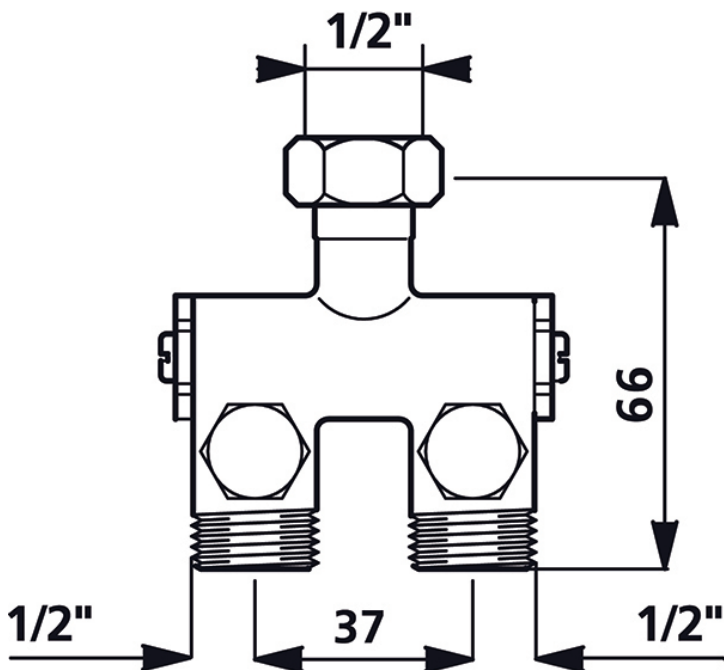
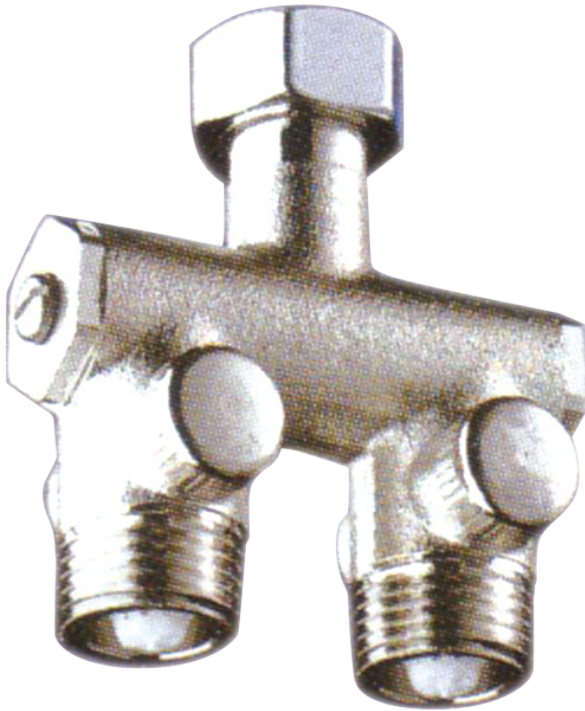

Dimensions are in millimeters. If a Cad file is required please visit www.mechline.com.



MECHLINE DEVELOPMENTS LIMITED
 Tel: +44 (0)1908 261511 | Email: info@mechline.com | Web: www.mechline.com