



## F60/100 - IMC Vulture 725 In-tabling Food Waste Disposer - 1 Phase - W 338 mm - 1.1 kW

Reliable, efficient, safe and easy to operate, the compact 725 Waste Disposer allows operators to quickly and effectively remove waste, to create a safer and cleaner kitchen.

- ✓ Fast and efficient disposal of up to 400kg of food waste per hour.
- ✓ Compact design allows hopper to be table-mounted, for quick and easy loading.
- ✓ Handles up to 850 covers per sitting - ideal for medium-size kitchens.
- ✓ Manually reversible motor to extend operational life.
- ✓ For medium waste (plate waste, vegetables and peelings, meat and fish scraps).
- ✓ Suitable for medium kitchens with single-phase power supply.

### Specifications

#### Summary

|                             |                                   |
|-----------------------------|-----------------------------------|
| <b>Brand</b>                | IMC                               |
| <b>Range</b>                | Vulture                           |
| <b>Series</b>               | 700 Series                        |
| <b>Power Type</b>           | Electric                          |
| <b>Unit Type</b>            | Welded into tabling               |
| <b>Available in UK Only</b> | No                                |
| <b>UK Warranty</b>          | 2 Years Parts and Labour Warranty |
| <b>Export Warranty</b>      | Contact your local dealer         |
| <b>Mounting</b>             | In-tabling                        |
| <b>GTIN</b>                 | 5056105199526                     |

#### Power and Performance

|                       |      |
|-----------------------|------|
| <b>Total Power kW</b> | 1.1  |
| <b>HP</b>             | 1.5  |
| <b>IP Rating</b>      | IP55 |

#### Key Specifications

|                        |                                 |
|------------------------|---------------------------------|
| <b>Operator Safety</b> | Interlocks                      |
| <b>WRAS Approved</b>   | WRAS Compliant [if cistern fed] |
| <b>Airbreak</b>        | No                              |

#### Capacity

|                             |              |
|-----------------------------|--------------|
| <b>Type of Waste</b>        | Medium waste |
| <b>Covers Per Sitting</b>   | 850          |
| <b>Capacity Kg per Hour</b> | 400          |

#### Weights and Dimensions

|                                  |      |
|----------------------------------|------|
| <b>Unit Height (External) mm</b> | 733  |
| <b>Unit Width (External) mm</b>  | 340  |
| <b>Unit Depth (External) mm</b>  | 472  |
| <b>Net Weight Kg</b>             | 39.5 |

#### Supply Connections

|                                       |   |
|---------------------------------------|---|
| <b>Requires Installation</b>          | Yes   |
| <b>Requires Electrical Supply</b>     | Yes   |
| <b>UK 3 Pin Plug</b>                  | No  |
| <b>Requires Hardwiring</b>            | Yes   |
| <b>Electrical Supply Rating Watts</b> | 1100  |
| <b>Single Phase Amps</b>              | 7.4   |
| <b>Single Phase Voltage</b>           | 230   |
| <b>Water Supplied From</b>            | Storage cistern                                   |
| <b>Water Connection Pressure Bar</b>  | 0.4   |
| <b>Drain Connection</b>               | 2" BSP threaded flange, connected to 54mm piping; |
| <b>Water Connection</b>               | 15mm  |

#### Shipping

|                         |       |
|-------------------------|-------|
| <b>Packed Weight Kg</b> | 43.45 |
| <b>Packed Height cm</b> | 104   |
| <b>Packed Width cm</b>  | 63    |
| <b>Packed Depth cm</b>  | 48    |

## Available Options

### MAG CUTLERY SAVER

VS167

700/800/904/904X MAGNETIC CUTLERY SAVER

### WATER FLOW CONTROL

VS355

725 WATER FLOW CONTROL

## Technical Picture

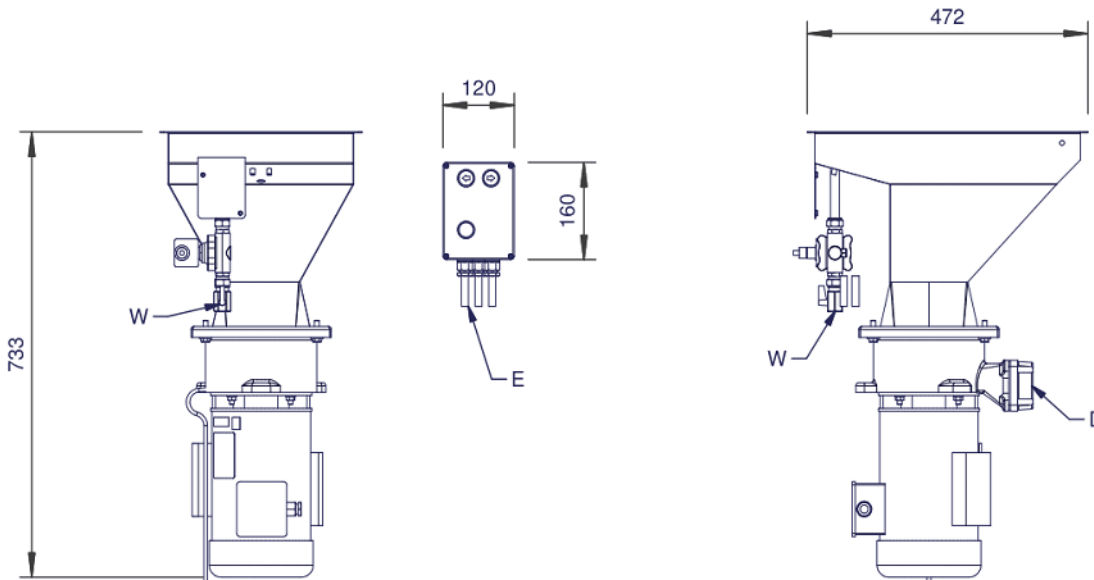
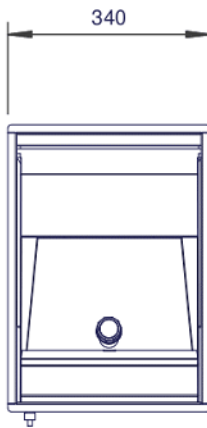



**Lincat Limited**

Whisby Road,  
Lincoln, LN6 3QZ,  
United Kingdom

**Company No:** 2175448

A member company of



**Customer Care**

**Tel:** +44 1522 875500  
**Email:** care@lincat.co.uk

**Export Customers**

**Tel:** +44 1522 875536  
**Email:** export@lincat.co.uk

**Opening Hours**

**Monday – Friday:**  
8.30am – 5pm