

MODEL:

BaSix BSX-400-WDS

BASIX

Drinks Station - wall mounted, complete with BSX-400 stainless steel basin, bottle filler & bubbler tap

Basin range: Drinks Station

Controls: Soft-touch

Connect: Connections: 3/8-inch BSP external thread and 1/4-inch BSP internal thread

Accredita: WRAS

FEATURES & BENEFITS

- WRAS approved
- Enables businesses to join the national drinking water scheme by offering easily accessible drinking water for staff, customers and the public
- Stylish, curved design. Ideal for public and staff areas, kitchens, changing/wash rooms
- Soft-touch press buttons with built in auto shut-off valve require no user effort
- Tall swan neck bottle filler and deep bowl accommodates large water bottles
- Depth of bowl reduces splashback and protects the floor from hazardous spills
- Overall design function encourages reuse and recycling of drinks containers, helping to protect the environment
- Chrome-plated water bubbler and water bottle filler are robust, corrosion resistant and easy to clean
- Adjustable flow screws allow the flow rates to be quickly and easily modified (using an Allen key)
- EPDM rubber o-rings
- Double filter, to ensure users a thick and uniform water flow, to increase hygienic use and convenience
- Supplied with x2 flexible connection hose - 10mm bore, 150mm length, 3/8-inch F x 15mm compression fittings
- Taps can be purchased separately
- Mounting bracket with integral spirit level supplied for fast and easy installation
- Easy to clean - integral flush grated waste
- Bowl and deck are permanently bonded to the skirt, removing the need for exposed bolts and rivets
- Optional high density polyethylene waste bin available

TECHNICAL INFO

- Materials: Bowl & Deck: High grade polished 304 Austenitic stainless steel Skirt: High grade, high strength injection moulded ABS-Polycarbonate Bubbler & bottle filler: Chrome plated
- Dimensions: O/D: 400 x 360 x 160mm Bowl: 358 x 310 x 130mm deep
- Connections: 3/8-inch BSP external thread
- Tap hole: 25-32mm

MAINTENANCE & CLEANING

Cleaning chrome: Do not use abrasive, chlorine or acid-based cleaning products. Avoid contact with concentrated bleach. Clean with soapy water using a cloth or sponge.

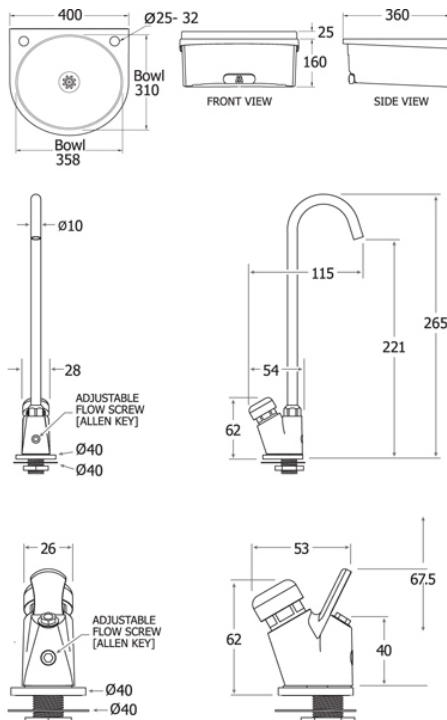

Dimensions are in millimeters. If a Cad file is required please visit www.mechline.com.



MECHLINE DEVELOPMENTS LIMITED

Tel: +44 (0)1908 261511 | Email: info@mechline.com | Web: www.mechline.com