

Refrigerated and Freezer counters

1/1 GN – Work Top depth 700 mm

2/1 GN – Work Top depth 800 mm



Innovative and functional food storage

The counter – the central point of the commercial kitchen

Quality gives job satisfaction

Hygiene and the chef's working environment are important factors in the day to day life of the commercial kitchen. Not only as a practical necessity, but also because the quality of the food and job satisfaction are affected.

The working environment

There are many aspects to creating an ideal working environment. This begins with the staff and their knowledge and experience. Additionally, it is about good design and the layout of the kitchen and having the best equipment to work with.

A central position

A refrigerated counter is the chef's prime workstation. Therefore it often occupies a central position in the kitchen.

Besides its storage function, the counter has a central role from preparation through to arranging and serving the food.



An answer for everything

These complex tasks require solutions which are reliable and practical, benefiting both food hygiene and the working environment.



What you get when you choose Gram

No product can stand alone

Even sophisticated products of a high technological standard need to offer an excellent back up service. This is the responsibility of the manufacturer and a key issue for Gram. It gives peace of mind when purchasing and during the entire life span of the product.

The GASTRO series – and what else Gram has to offer

This brochure presents the counter series GASTRO 07 and 08 which include counters and saladettes of 70 and 80 cm depth that can be built to suit your requirements.

Like all our other product ranges, GRAM GASTRO is based on environmentally friendly technology. Furthermore, the customer is supported in all crucial areas.

We are where you are

Gram co-operates with the best and most professional distributors. This means that you can rely on fast and competent service no matter where you are.

Delivery is more than simple transportation

Our Customer Service, sales consultants and service

providers form a strong team. We provide delivery to the doorstep and are at your disposal with technical support before and after the purchase of a Gram product.

A 3-year warranty gives peace of mind

We offer a free 3-year parts and labour warranty on all GASTRO counters. Service is carried out by specialists in refrigeration and freezing – giving you complete peace of mind.

Spare parts for up to 10 years

Spare parts are available for up to 10 years after purchase. This is something else Gram is pleased to offer.

On-line information for customers

At www.gram-commercial.com you can find detailed information on all commercial products from Gram.



Get all the way round your counter...

Hygiene

- 1 Stainless steel inside and outside, including wire shelves and drawer inserts
- 2 All counter tops come with a “drip nose edge” preventing ingress of water
- 3 Worktops with splash backs to prevent spillage behind the counter
- 4 Inside base shaped as a dished pan to catch fluids
- 5 Minimal screws and fixings and rounded corners optimise hygiene

Working environment

- 6 Anti-tilt shelves and pull-out stop on drawers helps prevent spillage
- 7 Removable drawer and door gaskets for easy cleaning
- 8 Extra long drawer telescope rails – GN-pans can be lifted in and out without tilting
- 9 Choice of castors or legs of alternative heights offer a correct working height
- 10 Or even better: Electric elevation for an entirely flexible working height

Technical Information

- 11 Natural refrigerants and insulation materials, entirely free of the greenhouse gas HFC
- 12 Intelligent digital control with the possibility of an additional CTS-alarm and datalogger
- 13 Optional lockable doors and drawer sets
- 14 A compact slide out refrigeration unit for easy maintenance, service access and minimal noise
- 15 Removable condenser filters help keep the refrigeration system in excellent condition

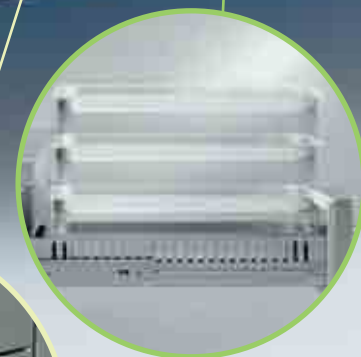



GRAM GASTRO

– adapts to your working day!

A member of the GRAM family

With its characteristic lines, GRAM GASTRO has the same design continuity as the latest generation of upright cabinets in the Gram family.

Technology and design go hand in hand. GRAM GASTRO uses environmentally friendly technology in the form of natural refrigerants and foaming agents and is exceptionally energy efficient.

More peace of mind - More options

GRAM GASTRO offers a wide variety of options, for example from the electronic elevation of the counter to the optional use of a datalogger for documentation. It's the requirements of the kitchen which matters – you decide!

The counter has a new electronic control as standard which offers numerous advantages and built-in safety systems.

Service and replacement

Servicing of the counter has been simplified as much as possible. The refrigeration system can be pulled out from the front.

Furthermore, GRAM GASTRO is modular allowing accessories to be adapted in line with the changing needs of the kitchen.



Notice: There is an additional charge if the Optional Extra of electronic elevation is chosen.

Because no two kitchens are exactly the same

The starting point for choosing the right refrigerated or freezer counter is the working process of your own kitchen. Refrigerated counters, for instance, can be used in production lines from raw materials to finished items or, alternatively, for cold buffets in hotels, restaurants and other large establishments.

Additionally, a double work station with pass-through might be requested or the counter could be used as a serving station.

The freezer counter also has various applications, for instance as a work table and storage unit in a bake-off sales outlet, as storage in large kitchens with a need for readily available frozen items, or for small kitchens where space has to be utilised to the maximum.

The GASTRO 07 series comprises of 1/1 Gastronorm counters, available with two, three or four sections. Flat worktop or saladette worktop. With or without splashback. Doors or drawers, with or without lock. Drawers however are only available in refrigeration counters.



The GASTRO 08 series comprises of 2/1 Gastronorm counters available with two or three sections. Flat worktop or saladette worktop. With or without splashback. With or without gantry. Doors on one or two sides, with or without lock.



Pass-through counters with doors on two sides offer even better access and an even higher degree of utilisation of the counter when used as a double work station. Only refrigeration counters are offered as pass-through counters.

Both series are available with or without compressor, with castors, legs, on plinth or with electronic elevation. Choose between standard refrigeration (+2/+12°C), extended refrigeration (-5/+12°C) or freezing (-25/-5°C).





GRAM





Open up and see your new colleague...



GRAM GASTRO – the name



of a strong partnership!



A strong partnership in the kitchen

The counter has a busy and changeable life in the commercial kitchen. During the day many varied jobs are carried out – often by a number of staff members.

Therefore the counter must fulfil a variety of functions in an efficient and user-friendly manner. The good workstation has ergonomic solutions to everything from food preparation and cleaning to service and maintenance.

In addition it has to be reliable and adaptable to the changing needs of the kitchen. It is possible to re-arrange features, such as door hinging, drawers, the tabletop and the internal configuration.

In addition, the visual appearance is a key customer requirement. A modern design and style is an extra asset to the kitchen.

Choose a partnership with GRAM GASTRO and you can concentrate on the more important things in your kitchen.

Choose Gram – and then forget all about it.

GRAM GASTRO 07 is available with 2, 3 or 4 refrigerated sections which are called GRAM GASTRO 1407, 1807 and 2207.

GRAM GASTRO 08 is available with 2 or 3 refrigerated sections which are called GRAM GASTRO 1808 and 2408.

Build your own work place with GASTRO 07

Work tops

1. Insulation board (i.e. without work top)
2. Flat worktop without splashback
3. Flat worktop with 50 mm splashback
4. Flat worktop with 100 mm splashback
5. Saladette work top with 50 mm splashback
6. Saladette worktop without splashback
7. Insulated lid or acrylic lid for saladette worktop

The counter is also available without worktop or insulation board.

In addition, a gantry with 2 shelves can be fitted onto the worktop.

Doors and drawer options

Each of the refrigerated sections are available with door or drawer sets (not freezer counters). The counter comes with or without a lock on all door/drawer sections.

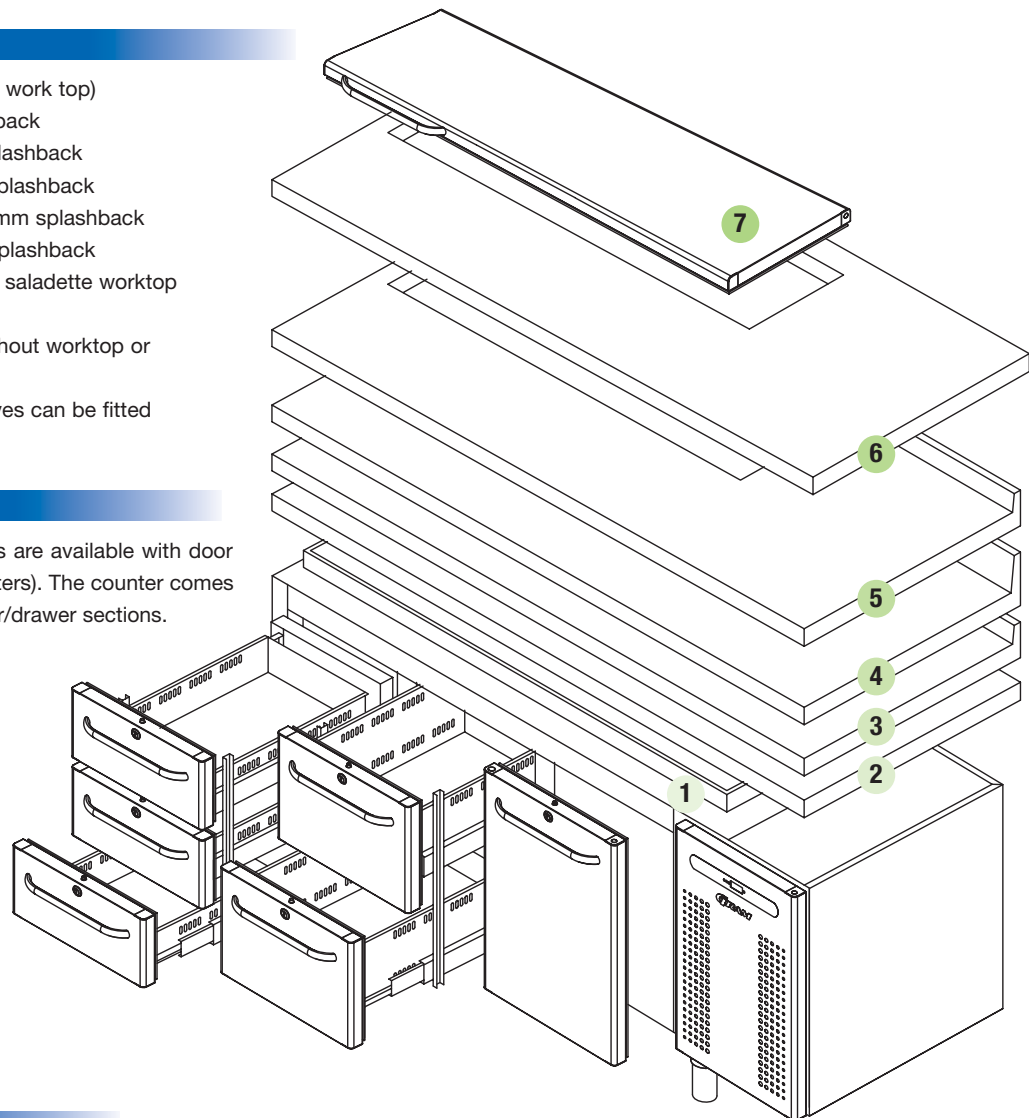
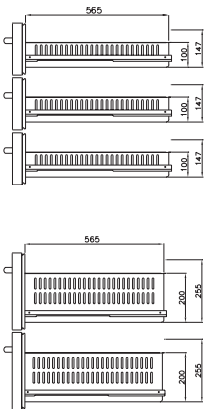

Accessories

Stainless shelves
Support sets for GN-pans
Wirebaskets

Optional Extras:
Extra shelves
Condenser filters
Exterior stainless steel cabinet polish
Wood or plastic cutting boards

Temperature ranges

Refrigeration: +2/+12 °C
Extended refrigeration: -5/+12 °C
Freezing: -25/-5 °C

electric elevation

Legs:	Counter height:
H = 100/135 mm	850/885 mm
H = 135/200 mm	885/950 mm
H = 185/250 mm	925/1000 mm

Castors:	Counter height:
H = 127 mm	877 mm
H = 155 mm	905 mm
H = 177 mm	927 mm
H = 205 mm	955 mm

Mounting on plinth: Plinth height + 750 mm

Electric elevation: H = 850/1050 mm

Electric elevation is only available for counters with internal compressor.

... or with GASTRO 08

Work tops

1. Insulation board (i.e. without work top)
2. Flat worktop without splashback
3. Flat worktop with 50 mm splashback
4. Saladette worktop without splashback
5. Insulated lid or acrylic lid for saladette worktop

The counter is also available without worktop or insulation board.

In addition, a gantry with 2 shelves can be fitted onto the worktop.

Doors with or without lock

Each of the refrigerated sections are available with door sets, with or without lock.

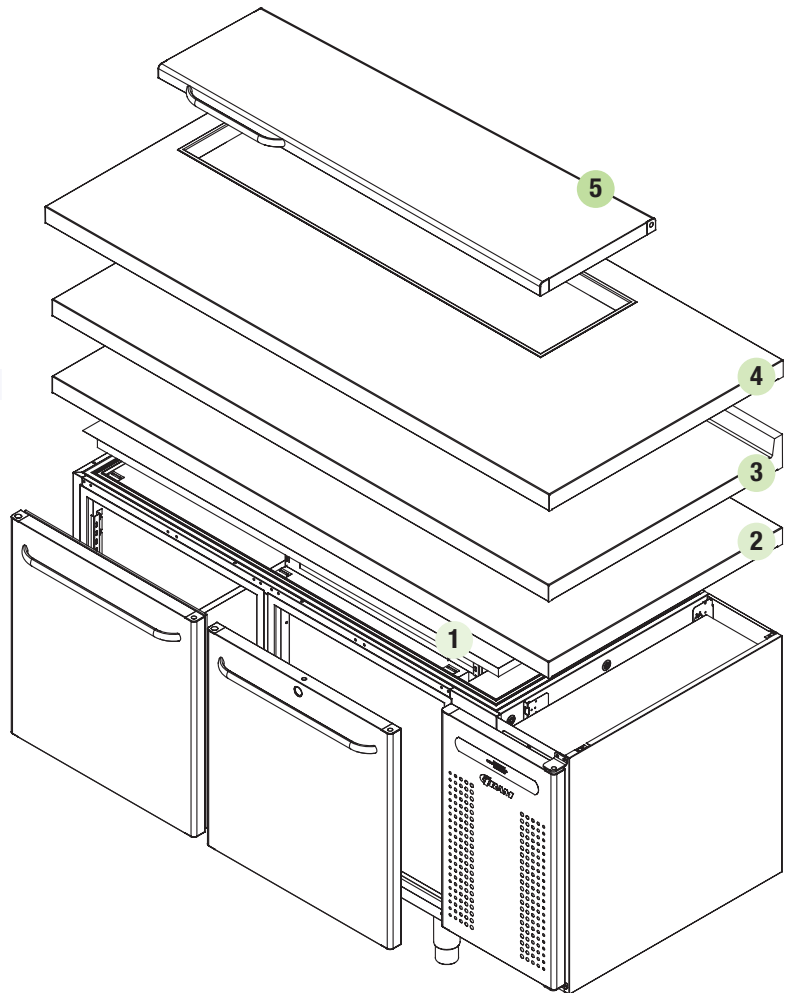

Accessories

Stainless shelves
Support sets for GN-pans
Bakery supports

Optional Extras:
Extra shelves
Condenser filters
Exterior stainless steel cabinet polish
Wood or plastic cutting boards

Temperature ranges

Refrigeration: +2/+12 °C
Extended refrigeration: -5/+12 °C
Freezing: -25/-5 °C

Legs, castors, on plinth or with electric elevation

Legs:	Counter height:
H = 100/135 mm	850/885 mm
H = 135/200 mm	885/950 mm
H = 185/250 mm	925/1000 mm

Castors:	Counter height:
H = 127 mm	877 mm
H = 155 mm	905 mm
H = 177 mm	927 mm
H = 205 mm	955 mm

Mounting on plinth: Plinth height + 750 mm

Electric elevation: H = 850/1050 mm

Electric elevation is only available for counters with internal compressor.

Building blocks in the 1/1 GN counter series

Standard specification and accessories

GASTRO 07 can be used as an island suite or be placed against a wall – and if necessary under an existing worktop.

The counter series is available with 2, 3 or 4 refrigerated sections. Inside and outside surfaces are made of stainless steel.

The height of the counter is 750 mm + the chosen legs/castors. The worktop depth is 700 mm.

Starting from a standard cabinet, the table below shows all available equipment options at a glance.



Freezing counter model F 1407

GRAM GASTRO 07 Refrigerated Counters

✓ Standard Model		Code	1407 CS	1807 CS	2207 CS
● As standard	Footprint (BxD), mm		1289x700	1726x700	2163x700
○ Optimal Equipment	Height, mm		885/950	885/950	885/950
Temperature range	Refrigeration, +2/+12°C	K	✓	✓	✓
	Medium, -5/+12°C	M	✓	✓	✓
	Freezing, -25/-5°C	F	✓	✓	✓
Materials	External		Stainless	Stainless	Stainless
	Interior		Stainless	Stainless	Stainless
Equipped with	Number of doors / sections		2	3	4
	Number of stainless shelves (325x530 mm)		4	6	8

Exterior Equipment		A	●	●	●
	Flat worktop	A	●	●	●
	Flat worktop with 50 mm splashback	A5	○	○	○
	Flat worktop with 100 mm splashback	A1	○	○	○
	Insulating board - without worktop	B	○	○	○
	Saladette worktop	S	○	○	○
	Saladette worktop with 50 mm splashback	S5	○	○	○
	Insulated hinged night lid for saladette	-L	○	○	○
	Gantry with 2 shelves	O	○	○	○
	Perspex night lid for saladette	-PL	○	○	○
	Door sections (right / left hand hinged)	DR/DL	●	●	●
	Drawer section with 2 x 1/2 drawer	2D	○	○	○
	Drawer section with 3 x 1/3 drawer	3D	○	○	○
	Locks	LC	○	○	○
	Castors (H = 155 mm)	C2	●	●	●
	Legs (H = 135/200 mm)	L2	○	○	○
	Cabinet prepared for plinth mounting	P	○	○	○
Electronic elevation - ergonomic flexibility	V	○	○	○	
Interior Equipment	Built-in datalogger	L	○	○	○
	Additional stainless shelves		○	○	○
	Grey wirebaskets (2 of) instead of shelf		○	○	○
Refrigeration	R 290	CSG	●	●	●
	R 134 a	CSH	○	○	○
	R 404 A	CSH	○	○	○
	Remote	CSF	○	○	○
	Brine cooling	CSS	○	○	○

Technical data

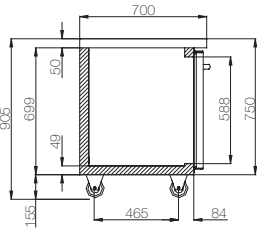

1407 CS 1807 CS 2207 CS

K M F K M F K M F

Temperature range	°C	+2/+12°	-5/+12°	-25/-5°	+2/+12°	-5/+12°	-25/-5°	+2/+12°	-5/+12°	-25/-5°
Refrigeration capacity at -10°C	Watt	345			345			345		
Refrigeration capacity at -25°C	Watt		550				550			640
Electrical connection	V/Hz	230/50								
Connection load	Watt	279	343	382	279	350	483	279	356	489
Amperage	A	1.8	2	2.4	1.8	2.1	2.5	1.8	2.1	2.5
Climate class		5								
Volume, gross	l	347			509			670		
Weight, gross	Kg	142			179			216		

Data in accordance with EN 441. Gram reserves the right to alter specifications without notice as a result of product development.

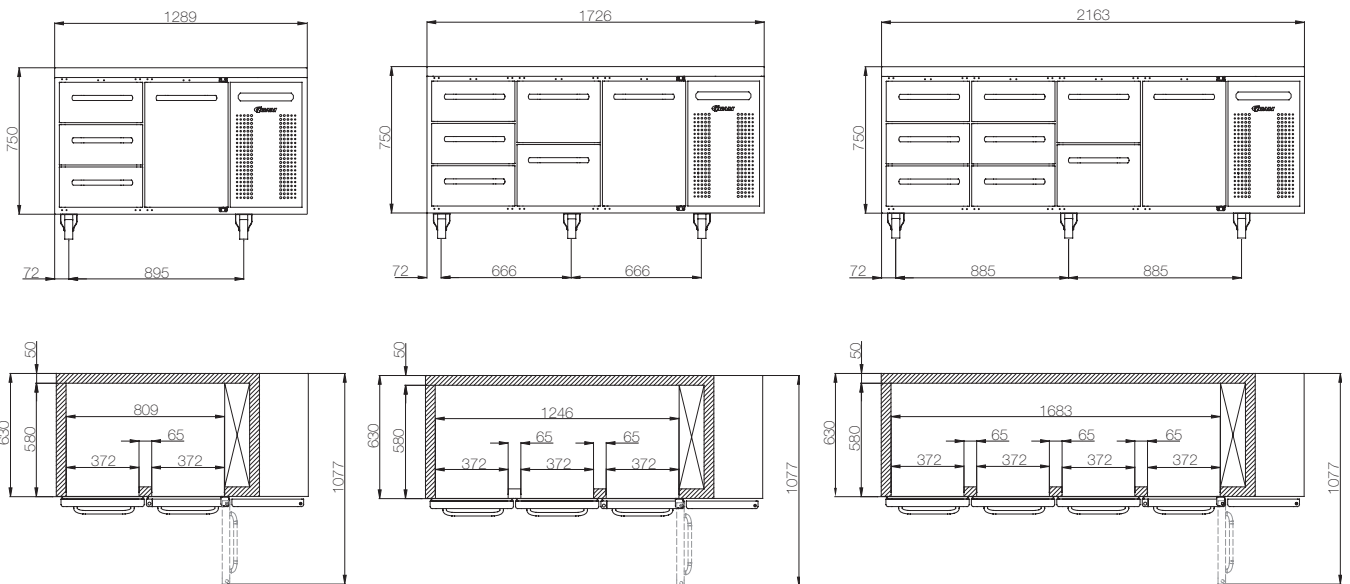

SALADETTE CUT OUT SIZES

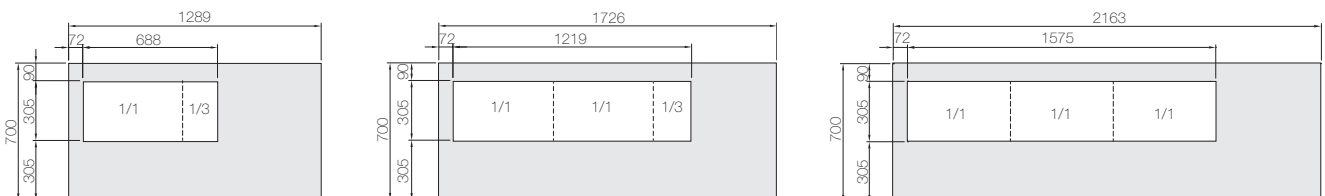

Building blocks in the 2/1 GN counter series

Standard specification and accessories

GASTRO 08 can be used as an island suite, with or without pass-through, or be placed against a wall – and if necessary under an existing worktop.

The counter series is available with 2 or 3 refrigerated sections. Inside and outside surfaces are made of stainless steel.

The height of the counter is 750 mm + the chosen legs/castors. The worktop depth is 800 mm.

Starting from a standard cabinet, the table below shows all available equipment options at a glance.



Freezing counter model F 1808

GRAM GASTRO 08 Refrigerated Counters

✓ Standard Model ● As standard ○ Optinal Equipment		Code	1808 CS	1808 D CS	2408 CS	2408 D CS
	Footprint (BxD), mm		1700x800	1700x870	2340x800	2340x870
	Height, mm		885/950	885/950	885/950	885/950
Temperature range	Refrigeration, +2/+12°C	K	✓	✓	✓	✓
	Medium, -5/+12°C	M	✓		✓	
	Freezing, -25/-5°C	F	✓		✓	
Materials	External		Stainless	Stainless	Stainless	Stainless
	Interior		Stainless	Stainless	Stainless	Stainless
Equipped with	Number of doors / sections		2	2	3	3
	Number of stainless shelves (530x650 mm)		4	4	6	6

Exterior Equipment	Flat worktop	A	●	●	●	●
	Flat worktop with 50 mm splashback	A5	○	○	○	○
	Insulating board - without worktop	B	○	○	○	○
	Saladette worktop	S	○	○	○	○
	Insulated hinged night lid for saladette	-L	○	○	○	○
	Perspex night lid for saladette	-PL	○	○	○	○
	Gantry with 2 shelves	O	○	○	○	○
	Door sections (right / left hand hinged)	DR/DL	●	●	●	●
	Locks	LC	○	○	○	
	Castors (H = 155 mm)	C2	●	●	●	●
	Legs (H = 135/200 mm)	L2	○	○	○	○
	Cabinet prepared for plinth mounting	P	○	○	○	○
	Electronic elevation - ergonomic flexibility	V	○	○	○	○
Interior Equipment	Built-in datalogger	L	○	○	○	○
	Additional stainless shelves		○	○	○	○
	9 bakery support sets (instead of shelves)		○	○	○	○
Refrigeration	R 290	CSG	●	●	●	●
	R 134 a	CSH	○	○	○	○
	R 404 A	CSH	○	○	○	○
	Remote	CSF	○	○	○	○
	Brine cooling	CSS	○	○	○	○

Technical data

		1808 CS			2408 CS		
		K	M	F	K	M	F
Temperature range	°C	+2/+12°	-5/+12°	-25/-5°	+2/+12°	-5/+12°	-25/-5°
Refrigeration capacity at -10°C	Watt	345			345	643	
Refrigeration capacity at -25°C	Watt			550			640
Electrical connection	V/Hz	230/50					
Connection load	Watt	303	370	603	303	501	691
Amperage	A	1.89	2.18	3.08	1.89	2.85	3.64
Climate class		5	5	4	5	5	4
Volume, gross	l	588			868		
Weight, gross	Kg	184			212		

Data in accordance with EN 441. Gram reserves the right to alter specifications without notice as a result of product development.

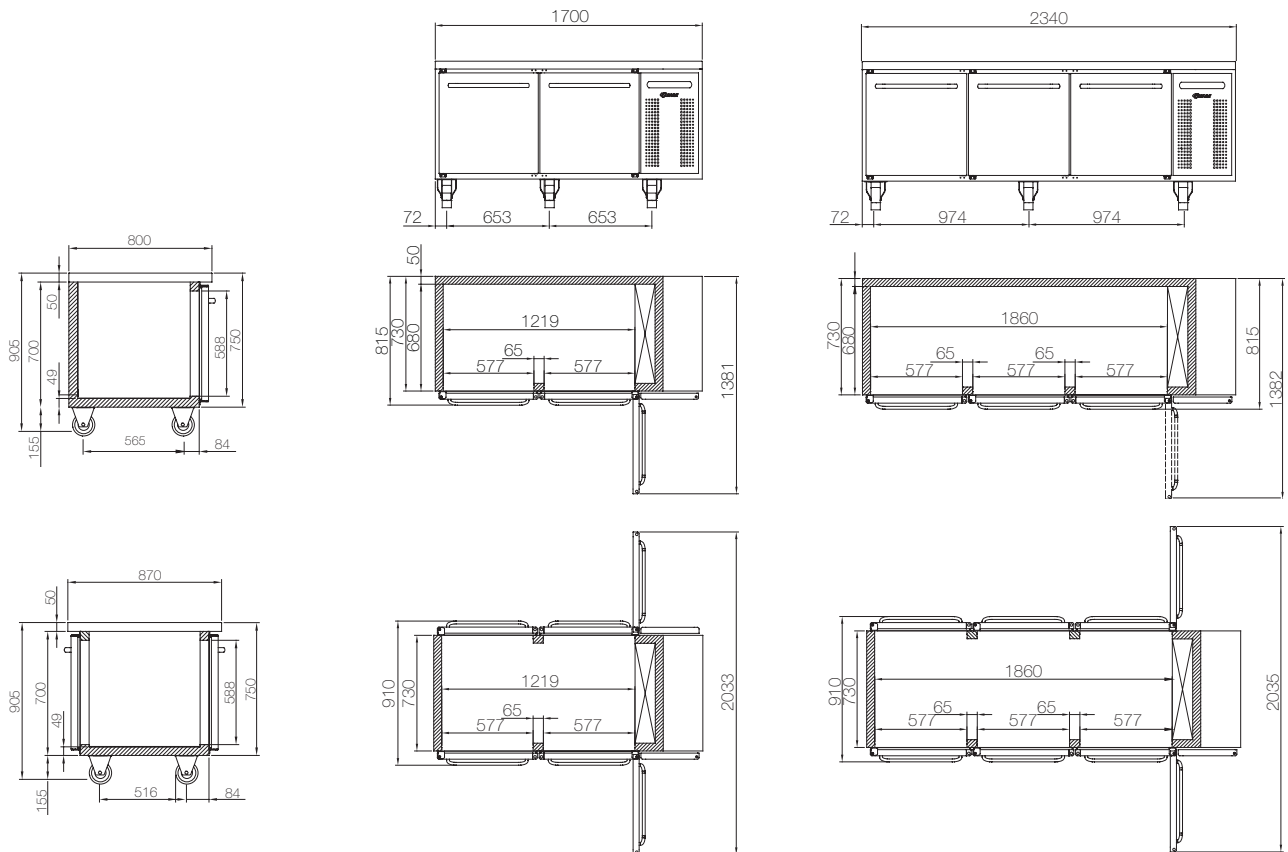

SALADETTE CUT OUT SIZES

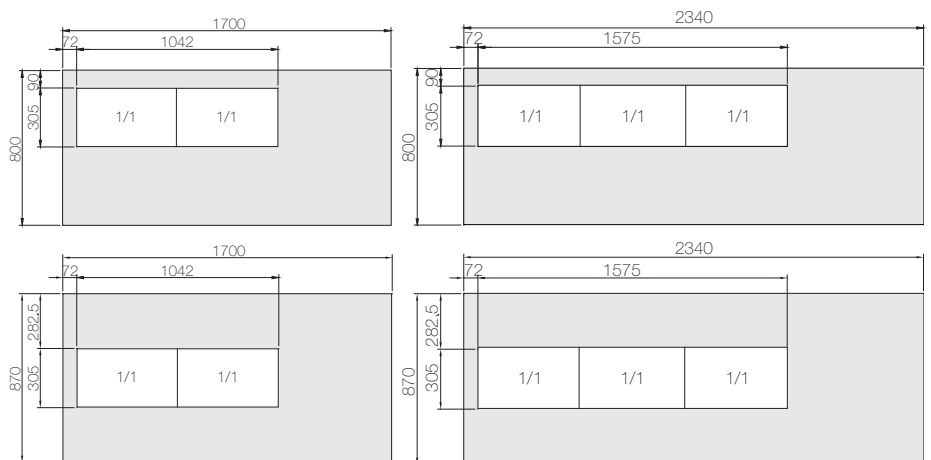

Contact

United Kingdom

Gram (UK) Ltd.
2 The Technology Centre
London Road
Swanley
Kent
BR8 7AG
Tel.: +44 1322 616900
Fax: +44 1322 616901
e-mail: info@gramuk.co.uk

Denmark

Head Office:
Gram Commercial A/S
Aage Grams Vej 1
DK-6500 Vojens
Tel.: +45 73 20 12 00
Fax: +45 73 20 12 01
e-mail: info@gram-commercial.com

Sweden

Gram Commercial
Box 5157
S-20071 Malmö
Tel.: +46 40 98 78 48
Fax: +46 40 98 78 49
e-mail: info@gram-commercial.com

Norway

Gram Commercial NUF
P.b. 44
N-1970 Hemnes
Tel.: +47 22 88 17 50
Fax: +47 22 88 17 51
e-mail: info@gram-commercial.com

Germany

Gram Deutschland GmbH
Holztorstraße 60
D-31157 Sarstedt
Tel.: +49 5066 - 60 46 - 0
Fax: +49 5066 - 60 46 - 49
e-mail: info@gram-commercial.com

The Netherlands

Gram Nederland B.V.
Postbus 601
NL-7600 AP Almelo
Tel.: +31 546 454252
Fax: +31 546 813455
e-mail: info@gram.nl

www.gram-commercial.com

Dealer:



Facts about us

Gram Commercial A/S develops and produces refrigerators and freezers for commercial kitchens. With our head office in Vojens, Denmark, and an extensive network of dealers around the world, we provide expert local service to our customers everywhere.