

DITO

Electrolux

Item

Model

Project Name



POTATO CHIPPER RC14

The potato chipper is designed to satisfy the requirements of restaurants, collective kitchens and food industries who need to cut a large quantity of chips in a short time.

FEATURES

- Body and drum are corrosion resistant.
- The hopper and cutter block are made of stainless steel.
- Drum and block are easy to remove.
- The hopper has a safety plate which allows potatoes to pass but not the hand of an operator.
- The machine will stop immediately if the hopper is opened during operation or if the cutter block is not properly fitted.
- The automatic feed is ideal for use in large catering kitchens and specialised chip production industries..
- The approximate output for 12 mm chips is approximately 25 Kg/min.

Vegetable slicers



DITO**Electrolux**

Specifications

MODEL	RC143 601151	RC14 601229	RC14C 601398
External dimensions - mm			
width	360	360	360
depth	670	670	670
height	560	560	560
Cutting capacity - kg/h			
chips	1500	1500	1500
Cutting capacity - kg/h			
potatoes	1500	1500	1500
Power - kW			
installed-electric	0.37	0.37	0.37
Supply voltage	230/400 V, 3, 50	230 V, 1+N, 50	115 V, 1+N, 60
Net weight - kg.	37	37	37

Included accessories

CODE	DESCRIPTION	RC143 601151	RC14 601229	RC14C 601398
653018	CHIPPING BLOCK 14 MM FOR POTATO CHIPPER			1

Optional accessories

CODE	DESCRIPTION	RC143 601151	RC14 601229	RC14C 601398
653023	CHIPPING BLOCK 10 MM FOR POTATO CHIPPER	✓	✓	✓
653024	CHIPPING BLOCK 12 MM FOR POTATO CHIPPER	✓	✓	✓
653018	CHIPPING BLOCK 14 MM FOR POTATO CHIPPER	✓	✓	✓
653022	CHIPPING BLOCK 8 MM FOR POTATO CHIPPER	✓	✓	✓
653503	CUTTING BLOCK 4MM FOR POTATO CHIPPER	✓	✓	✓
653504	CUTTING BLOCK 6MM FOR POTATO CHIPPER	✓	✓	✓
653505	CUTTING BLOCK 8MM FOR POTATO CHIPPER	✓	✓	✓
653017	S/S MOBILE STAND	✓	✓	✓



DITO

Electrolux

Installation drawings

601151, 601398, 601229

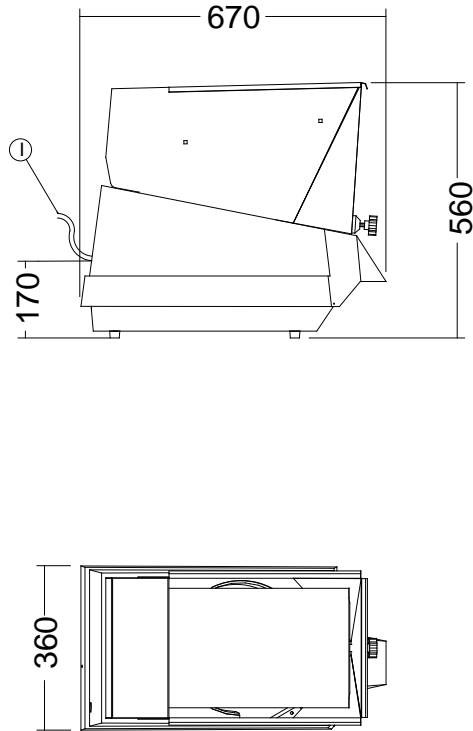

MODEL	RC143 601151	RC14 601229	RC14C 601398
I - Electrical connection	230/400 V, 3, 50	230 V, 1+N, 50	115 V, 1+N, 60

The manufacturer reserves the right to modify and make improvements to the products without giving prior warning. Dimensions, illustrations, technical data, weights, etc. are given as an indication only.



www.dito-electrolux.com

 **The Electrolux Group. The world's No.1 choice.**

Vegetable slicers



AAAH010