



# TRUE FOOD SERVICE EQUIPMENT, INC.

St. Charles Industrial Center • P.O. Box 970 • O'Fallon, Missouri 63366  
(636)240-2400 • FAX (636)272-2408 • (800)325-6152 • www.truemfg.com  
Parts Dept. (800)424-TRUE • Parts Dept. FAX# (636)272-9471

Project Name: \_\_\_\_\_

Location: \_\_\_\_\_

Item #: \_\_\_\_\_ Qty: \_\_\_\_\_

Model #: \_\_\_\_\_

A/A #

SIS #

Model:  
**T-23F**

**T Series:**  
*Reach-In Solid Door Freezer*



## T-23F

- ▶ True's solid door reach-in's are designed with enduring quality that protects your long term investment.
  - ▶ Designed using the highest quality materials and components to provide the user with colder product temperatures, lower utility costs, superior food safety and the best value in today's food service marketplace.
  - ▶ Extra large evaporator coil balanced with higher horsepower compressor and large condenser maintains -10°F (-23.33°C). Ideally suited for both frozen foods and ice cream.
  - ▶ 300 series stainless steel solid door and front. The very finest stainless for higher tensile strength for fewer dents and scratches.
  - ▶ Adjustable, heavy duty PVC coated shelves.
  - ▶ Positive seal self-closing door. Lifetime guaranteed door hinges and torsion type closure system.
  - ▶ Defrost system time-initiated, temperature-terminated. Saves energy consumption and provides shortest possible defrost cycle.
- Bottom mounted units feature:**
- ▶ "No stoop" lower shelf.
  - ▶ Storage on top of cabinet.
  - ▶ Compressor performs in coolest, most grease free area of kitchen.
  - ▶ Easily accessible condenser coil for cleaning.

## ROUGH-IN DATA

Specifications subject to change without notice.  
Chart dimensions rounded up to the nearest 1/8" (millimeters rounded up to next whole number).

Model	Solid Doors	Capacity (Cu. Ft.) (liters)	# of Shelves	Cabinet Dimensions (inches) (mm)			HP	Voltage	Amps	NEMA Config.	Cord Length (total ft.) (total m)	Crated Weight (lbs.) (kg)
				L	D†	H*						
T-23F	1	23 652	3	27 686	29 1/2 750	78 3/8 1991	1/2 1/2	115/60/1 230-240/50/1	10.4 5.5	5-15P ▲	9 2.74	295 134

\* Height does not include 5" (127 mm) for castors or 6" (153 mm) for optional legs.

▲ Plug type varies by country.



### APPROVALS:

Model:  
**T-23F**

**T Series:**  
Reach-In Solid Door Freezer



## STANDARD FEATURES

### DESIGN

- True's commitment to using the highest quality materials and oversized refrigeration systems provides the user with colder product temperatures, lower utility costs, superior food safety and the best value in today's food service marketplace.

### REFRIGERATION SYSTEM

- Factory engineered, self-contained, capillary tube system using environmentally friendly (CFC free) R404A refrigerant.
- Extra large evaporator coil balanced with higher horsepower compressor and large condenser maintains -10°F (-23.33°C). Ideally suited for both frozen foods and ice cream.
- Sealed, cast iron, self-lubricating evaporator fan motors and larger fan blades give True reach-in's a superior low velocity, high volume airflow design. This unique design insures faster temperature recovery and shorter run times in the busiest of food service environments.
- Bottom mounted condensing unit positioned for easy cleaning. Compressor runs in coolest and most grease free area of the kitchen. Allows for storage area on top of unit.
- Defrost system time-initiated, temperature-terminated. Saves energy consumption and provides shortest possible defrost cycle.

### CABINET CONSTRUCTION

- Exterior - 300 series stainless steel front grill and shroud. Anodized quality

- aluminum exterior ends and back.
- Interior - attractive, NSF approved, white aluminum liner. 300 series stainless floor with coved corners.
- Insulation - entire cabinet structure and solid door is foamed-in-place using high density, CFC free, polyurethane insulation.
- Cabinet mounted on a welded, heavy duty galvanized frame rail. Rail dipped in rust inhibiting enamel paint for corrosion protection inside and out.
- Cabinet mounted on a welded, heavy duty galvanized frame rail. Rail dipped in rust inhibiting enamel paint for corrosion protection inside and out.
- Frame rail fitted with 4" (102 mm) diameter stem castors standard - locks provided on front set.

### DOORS

- 300 series stainless steel exterior with white aluminum door liner to match cabinet interior. Door extends full width of cabinet shell. Door lock standard.
- Positive seal self-closing door. Lifetime guaranteed door hinges and torsion type closure system.
- Lifetime guaranteed recessed door handle. Each door fitted with 12" (305 mm) long recessed handle that is foamed-in-place with a sheet metal interlock to insure permanent attachment.
- Magnetic door gasket of one piece construction, removable without tools for ease of cleaning.

### SHELVING

- Three (3) adjustable, heavy duty PVC coated wire shelves 22 7/8" L x 23 1/4" D (582 mm x 591 mm). Four (4) chrome plated shelf clips to be included per shelf.
- Shelf support pilasters made of same

material as cabinet interior; shelves are adjustable on 1/2" (13 mm) increments.

### LIGHTING

- Incandescent interior lighting - safety shielded. Lights activated by rocker switch mounted above door.

### MODEL FEATURES

- Exterior mounted temperature monitor.
- Evaporator is epoxy coated to eliminate the potential of corrosion.
- Floor rack and rear airflow guards standard. Prevents product from blocking optimal airflow.

### ELECTRICAL

- Unit completely pre-wired at factory and ready for final connection to a 115/60/1 phase - 15 amp dedicated outlet. Cord and plug set included.



115/60/1  
NEMA-5-15R

### OPTIONAL FEATURES/ACCESSORIES

- 230-240V/50 Hz.
- 6" (153 mm) stainless steel or seismic legs.
- Additional shelves.
- Half and full door bun tray racks accommodates 18" x 26" (458 mm x 661 mm) sheet pans (airflow guards need to be removed).
- Remote cabinets (condensing units from factory or others), consult factory technical service department for BTU information.

## PLAN VIEW

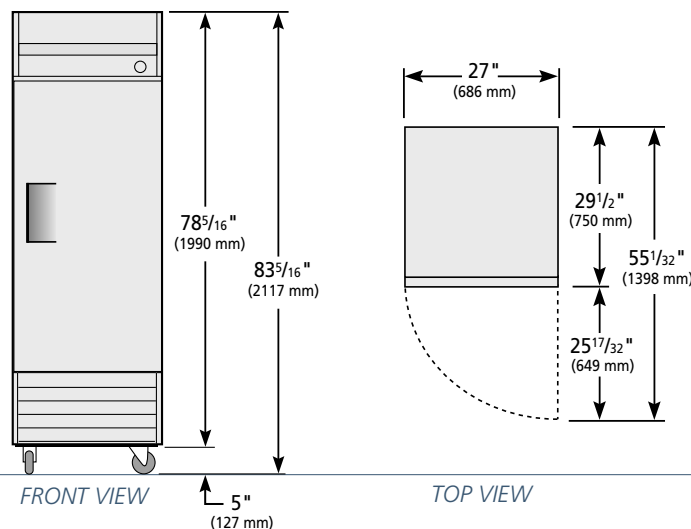

### WARRANTY

One year warranty on all parts & labor and an additional 4 year warranty on compressor. (U.S.A. only)

METRIC DIMENSIONS ROUNDED UP TO THE NEAREST WHOLE MILLIMETER

SPECIFICATIONS SUBJECT TO CHANGE WITHOUT NOTICE



Model	Front	Side	Plan	3D
T-23F	TFEY03E	TFEY03S	TFEY03P	TFEY033

## TRUE FOOD SERVICE EQUIPMENT

St. Charles Industrial Center • P.O. Box 970 • O'Fallon, Missouri 63366 • (636)240-2400 • FAX (636)272-2408 • (800)325-6152 • www.truemfg.com