



Excellence since 1928

SP RANGE

SP 80, 100, 200
SP 30HI, 40HI, 60HI MIXING MACHINES

METCALFE SP 80, 100, 200, 30HI, 40HI, 60HI PLANETARY MIXERS

The Metcalfe range of planetary mixers combine rugged durability with safety and style to cater for today's exacting environment. Their 3-speed transmission delivers power to fulfil all mixing requirements.

In addition to this, the Metcalfe SP Mixers are fully CE Approved with an electrically interlocked bowl guard and bowl lift.

Particularly suitable for bakeries, hotels, restaurants, canteens etc.

All models supplied with bowl, beater, whisk, dough hook and attachment hub.

The Metcalfe SP80, 100 and 200 are supplied with a 13amp plug whereas the SP30HI, 40HI and 60HI need to be hard wired into an isolator.



SPECIFICATIONS						
Model	Dimensions DxWxH mm	Bowl Size Qts (Ltr)	Weight (net) lbs (kg)	Electrics	HP	Speed
SP-80	470 x 360 x 660	8 (7.5)	63 (29)	220/240/1	¼	132.284.590
SP-100	450 x 410 x 770	10 (9)	143 (65)	220/240/1	⅓	106.196.358
SP-200	520 x 500 x 890	21 (20)	220 (100)	220/240/1	½	106.196.358
SP-30HI	665 x 568 x 1156	31 (30)	396 (180)	220/240/1 380/415/3	1	99.176.320
SP-40HI	720 x 630 x 1300	42 (40)	550 (250)	220/240/1 380/415/3	1½	99.176.320
SP-60HI	720 x 630 x 1300	63 (60)	621 (270)	220/240/1 380/415/3	2½	99.176.320

THE SP RANGE OF MIXERS
 DETAILS AND SPECIFICATIONS

SP 80

The SP 80 is a durable, counter top planetary mixer designed for commercial use.

It has a total bowl capacity of 8 Quarts (7.5Ltr) combined with a 3 speed gearbox to ensure all mixing requirements can be met. This mixer also has a fully integrated digital timer.

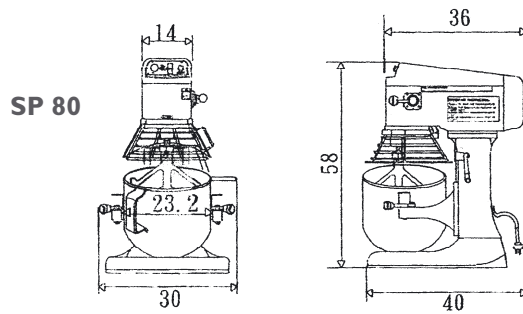

SP 100 + 200

The SP 100 + 200 are commercial bench mounted planetary mixers.

The SP 100 has a capacity of 10 Quarts (9Ltr) and the SP 200 has a capacity of 21 Quarts (20Ltr). Both machines have a 3 speed gear box to deliver enough power to fulfil all mixing requirements.

SP 100

SP 200

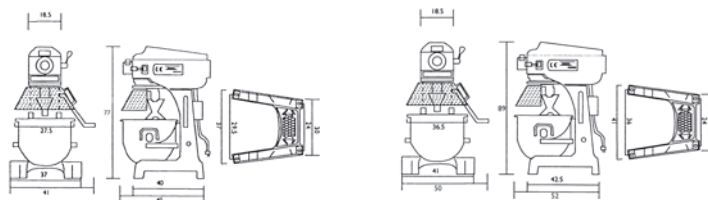

SP 30HI SP 40HI SP 60HI SP 80HI

This range of SP mixers are all floor standing models designed for commercial use.

The 30HI has a bowl capacity of 31 Quarts (30Ltr)
 The 40HI has a bowl capacity of 42 Quarts (40Ltr)
 The 60HI has a bowl capacity of 63 Quarts (60Ltr)
 The 80HI has a bowl capacity of 84 Quarts (80Ltr)*

* Please contact the sales office for details on the 80HI (special order)

All the range have fully integrated timers.

SP 30HI

SP 40HI + 60HI

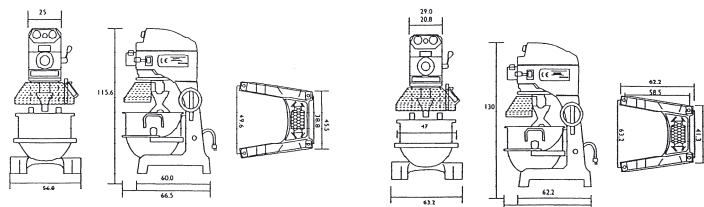



PRODUCT FEATURES

- All Models come complete with stainless steel bowl, whisk, dough hook and beater
- CE Approved
- Fully interlocked bowl guard and bowl lift.
- 10 Quart conversion parts are available at extra cost for SP200 model
- 3 Speed Gearbox
- No-Volt Release
- Emergency Stop
- Resettable Thermal Overload
- Easy to Operate.



OPTIONAL EXTRAS

VH-12 MINCER ATTACHMENT

This no.12 Mincing Attachment is ideal for meat, fish and other foods. It is supplied with a stainless steel feed pan, sausage filler and stomper.



V99S VEGETABLE ATTACHMENT

This versatile attachment comes with an adjustable blade assembly in addition to 6 plates to grate or shred all types of vegetables and fruit.



STAND AND MOBILE TROLLEY

A stand and mobile trolley are available at extra cost for the for the SP-100 and SP-200.

BOWL TROLLEY

A bowl trolley is available at extra cost for the SP-30HI, SP-40HI and SP-60HI.

Covered by Metcalfe 12 Month Guarantee & Full After Sales Service.



SP 80		Maximum regular mix (kg)	Whisk	Beater	Dough Hook
Product					
Mashed potato	2.1		•	•	
Pie pastry	2.1		•		
Fruit cake	5.2		•		
Sponge cake	1.4		•	•	
Pound cake	2.1		•		
Madeira	3.8		•		
Steam pudding	3.8		•	•	
Fondant (kg sugar)	1.4		•		
Whipping cream	1.1 litres		•		
Egg whites	0.2 litres		•		
Mayonnaise	2.2 litres		•		
Batter	3.0 litres		•	•	
Meat	4.0		•	•	
Croissants (kg flour)	2.0			•	
Brioche (kg flour)	3.2			•	
Light bread dough-2 (65% moisture content)	2.0			•	
Heavy bread dough-2 (60% moisture content)	1.8			•	
Pizza dough-2 (50% moisture content)	1.5			•	
Pizza dough-2 (40% moisture content)	1.2			•	

SP 100		Maximum regular mix (kg)	Whisk	Beater	Dough Hook
Product					
Mashed potato	5.8		•	•	
Pie pastry	4.2		•		
Fruit cake	6.5		•		
Sponge cake	3.2		•	•	
Pound cake	4.5		•		
Madeira	4.5		•		
Steam pudding	4.5		•	•	
Fondant (kg sugar)	3.0		•		
Whipping cream	2.0 litres		•		
Egg whites	0.5 litres		•		
Mayonnaise	5.0 litres		•		
Batter	3.8 litres		•	•	
Meat	5.0		•	•	
Croissants (kg flour)	3.0			•	
Brioche (kg flour)	3.0			•	
Light bread dough-2 (65% moisture content)	5.7			•	
Heavy bread dough-2 (60% moisture content)	4.5			•	
Pizza dough-2 (50% moisture content)	2.3			•	
Pizza dough-2 (40% moisture content)	2.0			•	

SP 200		Maximum regular mix (kg)	Whisk	Beater	Dough Hook
Product					
Mashed potato	6.0		•	•	
Pie pastry	6.0		•		
Fruit cake	11.5		•		
Sponge cake	5.5		•	•	
Pound cake	8.0		•		
Madeira	8.0		•		
Steam pudding	8.0		•	•	
Fondant (kg sugar)	5.0		•		
Whipping cream	4.0 litres		•		
Egg whites	0.8 litres		•		
Mayonnaise	10.0 litres		•		
Batter	8.0 litres		•	•	
Meat	8.0		•	•	
Croissants (kg flour)	4.0			•	
Brioche (kg flour)	4.0			•	
Light bread dough-2 (65% moisture content)	8.5			•	
Heavy bread dough-2 (60% moisture content)	6.5			•	
Pizza dough-2 (50% moisture content)	5.5			•	
Pizza dough-2 (40% moisture content)	4.0			•	

SP 30HI		Maximum regular mix (kg)	Whisk	Beater	Dough Hook
Product					
Mashed potato	12.0		•	•	
Pie pastry	12.0		•		
Fruit cake	18.2		•		
Sponge cake	11.5		•	•	
Pound cake	14.0		•		
Madeira	16.0		•		
Steam pudding	16.0		•	•	
Fondant (kg sugar)	9.0		•		
Whipping cream	6.8 litres		•		
Egg whites	1.7 litres		•		
Mayonnaise	14.0 litres		•		
Batter	16.0 litres		•	•	
Meat	15.0		•	•	
Croissants (kg flour)	7.0			•	
Brioche (kg flour)	7.0			•	
Light bread dough-2 (65% moisture content)	15.0			•	
Heavy bread dough-2 (60% moisture content)	14.0			•	
Pizza dough-2 (50% moisture content)	10.0			•	
Pizza dough-2 (40% moisture content)	8.0			•	

SP 40HI		Maximum regular mix (kg)	Whisk	Beater	Dough Hook
Product					
Mashed potato	15.0		•	•	
Pie pastry	15.0		•		
Fruit cake	20.0		•		
Sponge cake	15.0		•	•	
Pound cake	18.0		•		
Madeira	20.0		•		
Steam pudding	20.0		•	•	
Fondant (kg sugar)	12.0		•		
Whipping cream	9.0 litres		•		
Egg whites	2.2 litres		•		
Mayonnaise	18.0 litres		•		
Batter	20.0 litres		•	•	
Meat	18.0		•	•	
Croissants (kg flour)	10.0			•	
Brioche (kg flour)	10.0			•	
Light bread dough-2 (65% moisture content)	20.0			•	
Heavy bread dough-2 (60% moisture content)	16.0			•	
Pizza dough-2 (50% moisture content)	12.0			•	
Pizza dough-2 (40% moisture content)	10.0			•	

SP 60HI		Maximum regular mix (kg)	Whisk	Beater	Dough Hook
Product					
Mashed potato	20.0		•	•	
Pie pastry	20.0		•		
Fruit cake	20.0		•		
Sponge cake	18.0		•	•	
Pound cake	23.0		•		
Madeira	29.0		•		
Steam pudding	29.0		•	•	
Fondant (kg sugar)	20.0		•		
Whipping cream	13.0 litres		•		
Egg whites	3.0 litres		•		
Mayonnaise	28.0 litres		•		
Batter	30.0 litres		•	•	
Meat	30.0		•	•	
Croissants (kg flour)	18.0			•	
Brioche (kg flour)	18.0			•	
Light bread dough-2 (65% moisture content)	40.0			•	
Heavy bread dough-2 (60% moisture content)	33.0			•	
Pizza dough-2 (50% moisture content)	14.0			•	
Pizza dough-2 (40% moisture content)	12.0			•	

- 1 Recommended weight for a finished mix unless otherwise stated.
- 2 Water content e.g. 25# Flour: 12.5# Water = 50% Moisture.
- 3 For pizza dough with lower moisture content consult Metcalfe.
- 4 For higher gluten flour reduce dough batch by 25%.

Stockists:

JustCatering.Com

Distributed By **JustCatering.Com Ltd**

10 Jessop Av, Norwood Green, Middlesex, UB2 5UY, UK

Tel: +44 (0) 845 0034271 Direct line +44 (0) 7006342365

Email sales@justcatering.com Web site www.justcatering.com

Metcalfe Catering Equipment Ltd

Haygarth Park, Blaenau Ffestiniog, Gwynedd, LL41 3PF, Great Britain

t +44 (0)1766 830 456

f +44 (0)1766 831 170

e enquiries@metcalfecatering.com

w www.metcalfecatering.com