



MF-RANGE

INSTALLATION AND OPERATING MANUAL
PLEASE LEAVE WITH OPERATOR



MF5, MF10 & MF15 – SERIES 1

Imperial Machine Company Limited
Harvey Road, Croxley Green
Herts. WD3 3AX
Tel: +44 (0)1923 718000
Fax: +44 (0)1923 777273
Service Tel: 01923 718017
Spares Tel: 01923 718018. Fax: 01923 896256

ECN 6275 March 2004

EC DECLARATION OF CONFORMITY

(Guarantee of Production Quality)

We, Imperial Machine Company Limited of:
Harvey Road, Croxley Green, Herts WD3 3AX, ENGLAND,
Declare under our sole responsibility that the machine

**MF5, MF10 & MF15 – SERIES 1**

As described in the attached technical documentation is in conformity with the Machine Safety Directive 89/392/EEC as amended by 91/368/EEC and 93/44/EEC and is manufactured under a quality system BS EN ISO 9001. It is also in conformity with the protection requirements of the Electro Magnetic Compatibility Directive 89/336/EEC and is manufactured in accordance with harmonised standards EN 55014-1 Emission and EN 55014-2 Immunity (plus product specific standards).

It also satisfies the essential requirements of the Low Voltage Directive 73/23/EEC amended by 93/68/EEC and is manufactured in accordance with standards BS EN 60335-1 and BS EN 60335-2-64.

A handwritten signature in blue ink, appearing to read 'Z Iqbal', is written over a dotted line.

Approved by Z Iqbal, Engineering Manager

.....

Signed at Croxley Green, Date

22nd March 2003

INDEX

| | |
|--------------------------------------------|-----------|
| GUARANTEE | 1 |
| DELIVERY | 1 |
| SAMPLE RATING LABEL | 1 |
| INTRODUCTION | 2 |
| DIMENSIONS | 2 |
| M5..... | 2 |
| M10 on stand..... | 3 |
| M15 on stand..... | 3 |
| INSTALLATION..... | 4 |
| MF5 Bench installation..... | 4 |
| MF5 Bench mounting points..... | 4 |
| Stand installation..... | 4 |
| ELECTRICITY SUPPLY CONNECTION | 5 |
| WATER SUPPLY | 6 |
| COMMISSIONING | 6 |
| OPERATION..... | 7 |
| OPTIONAL PLATES | 8 |
| Plate order numbers | 8 |
| SAFETY..... | 9 |
| CLEANING | 9 |
| MAINTENANCE | 10 |
| DO'S AND DON'TS..... | 10 |
| ORDERING SPARE PARTS | 10 |
| MATERIAL CONTENT | 10 |

GUARANTEE

This equipment is guaranteed by IMC for 2 years from the date of its purchase from IMC, or from one of its stockists, dealers or distributors. The guarantee is limited to the replacement of faulty parts or products and excludes any consequential loss or expense incurred by purchasers. Defects which arise from faulty installation, inadequate maintenance, incorrect use, connection to the wrong electricity supply or fair wear and tear are not covered by the guarantee.

Please observe these instructions carefully.

The guarantee applies in this form to installations within the United Kingdom.

DELIVERY

The packaged machine consists of:

| | |
|-------------------------------|------------------------|
| Peeler Unit | 1 |
| Peeling plate | 1 |
| Stand and filter basket | 1 (MF10 and MF15 only) |
| Water supply pipe and fixings | 1 |
| Instruction Booklet | 1 |

Please notify both the carrier and the supplier within three days of receipt if anything is missing or damaged.

Check that the correct machine has been supplied and that the voltage, marked on the rating plate, is suitable for the supply available. The rating plate is located at the back of the cylinder near the supply cable inlet.

SAMPLE RATING LABEL

Stick Rating label here

INTRODUCTION

This machine is intended for peeling and washing root vegetables, cleaning mussels and drying salad.

For the Installer:

These Instructions contain important information designed to help the user obtain the maximum benefit from the investment in an IMC MF Range Universal Peeler. Please read them carefully before starting work, and consult with the supplier in the event of any queries. Be sure to leave this Instruction Manual with the user after installation of the machine is complete.

DIMENSIONS

M5

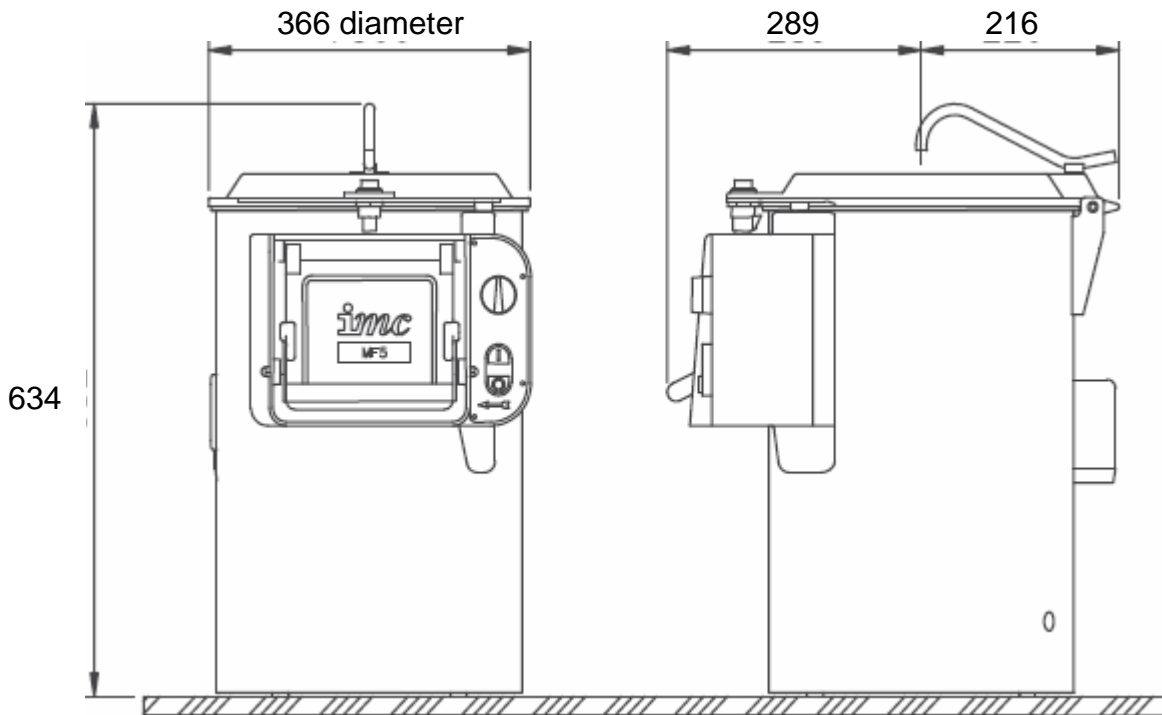

M10 on stand

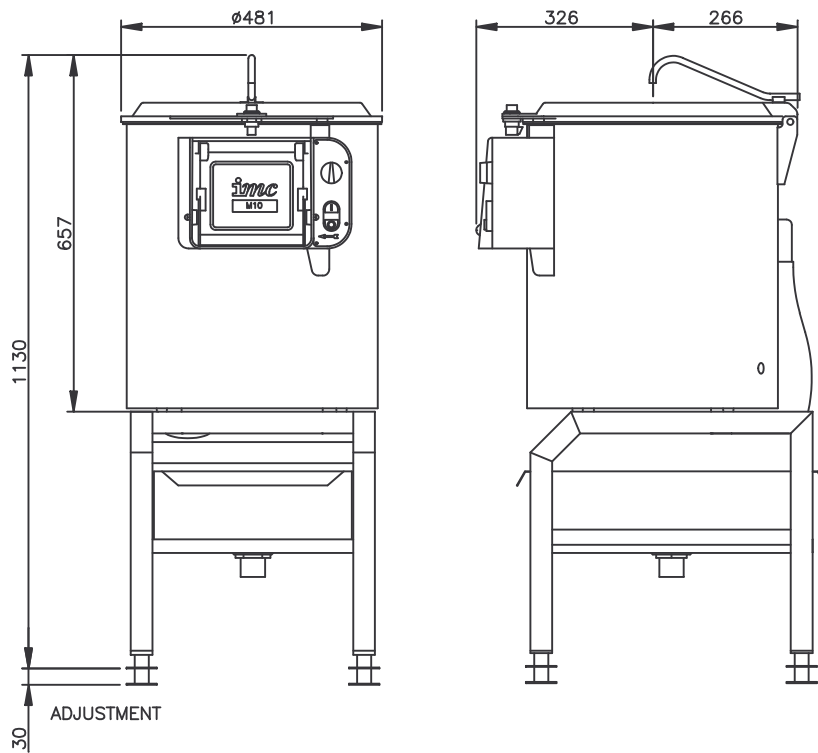

M15 on stand

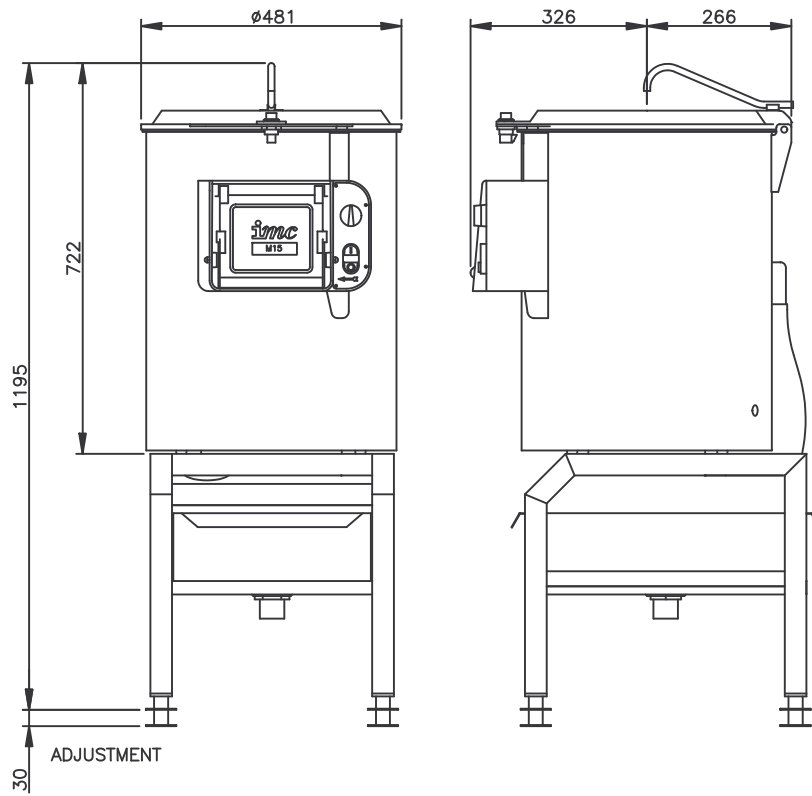

INSTALLATION

MF5 Bench installation

The MF5 is designed to stand on a bench, table, or on a draining board. DO NOT mount or operate the unit in a sink. Ensure that whatever is used for this purpose is sturdy and rigid and not more than 750 mm high. A higher table makes it difficult to load the machine. If the bench is sloping, or on a ship, the machine should be bolted to the bench using four M6x25 bolts and washers. All models are supplied with the waste pipe at the back, a longer pipe is available for MF5 bench top locations. A stainless steel stand, which includes a filter basket is available as an option.

MF5 Bench mounting points

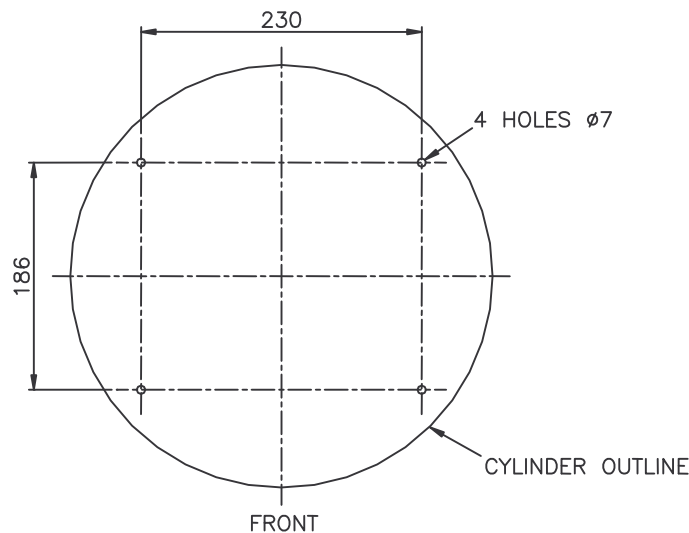

Stand installation

The MF10 & MF15 are supplied mounted on floor standing stands that incorporate filter baskets. The stand should be levelled using the adjustable feet. It is possible to fix the stand to the floor, if required, by screwing through to holes in the feet.

The waste is discharged from the waste hose via a Filter Basket into the drain tray of the stand, which has a 38mm waste pipe connection. This pipe may either discharge into a gully beneath the machine or it may be connected via a shallow seal waste trap and fixed pipework into the waste water system of the building.

ELECTRICITY SUPPLY CONNECTION

All electrical work must be carried out by a qualified electrician and in accordance with the IEE Codes of Practice. Before connecting, examine the rating plate attached to the machine to ensure that the characteristics shown are correct for the supply available. The peeler should be connected to a 30A isolator providing at least 3mm separation in all poles, ensure that the isolator is accessible with the peeler in place. The isolator should be fused at the ratings shown below:

| Supply | MF5 | MF10 | MF15 |
|---------------|-----|------|------|
| 230V – 1 – 50 | 10A | 15A | 15A |
| 400V – 3 – 50 | - | 4A | 4A |
| 230V – 3 – 50 | - | 15A | 15A |
| 208V – 3 – 60 | - | 15A | 15A |

The supply to the machine must also be protected by a 30mA RCD.

A new mains supply run to the machine should always be undertaken by an approved electrician. The IEE Codes of Practice must be observed.

The mains lead fitted to the machine is the minimum required for individual connection to the mains supply. Site conditions may vary with additional length of cable run, encapsulation in trunking, bunched with other cables etc. being required. Should this apply, the qualified electrician must alter the lead accordingly in accordance with the IEE Codes of Practice.

WARNING: This machine must be earthed

The wires in the mains lead for single phase supply are coloured:

| | |
|------------------|---------|
| Green and Yellow | Earth |
| Brown | Live |
| Blue | Neutral |

The wires in the mains lead for three phase supply are coloured:

| | |
|------------------|---------|
| Green and Yellow | Earth |
| Black | Phase 1 |
| Blue | Phase 2 |
| Brown | Phase 3 |

The 3 phase machines do not have a neutral wire, if the supply has a neutral wire isolate it and only wire the unit to the 3 phases and earth.

An equipotential bonding terminal is provided at the back of the unit near the cable outlet for external earth bonding. Provision of an earth bond does not remove the requirement for an earth in the electrical supply.

WATER SUPPLY

The water pipe is packed inside the machine for transit and should be fitted to the top of the lid using the screws provided.

The water supply pipe should be connected to an adjacent cold water supply using an IMC Inlet Hose Kit (Part No S58/062) or a 12mm (1/2") bore hose.

PLEASE NOTE: these machines are fitted with a Type A air-break to prevent back syphonage into the mains supply, but some local authorities may nevertheless require connection to a storage cistern rather than direct to the mains supply. This applies to UK installations, overseas customers should install the machine in accordance with local regulations.

IF IN DOUBT, CHECK WITH YOUR LOCAL AUTHORITY

COMMISSIONING

After making the electrical connection, switch on the machine, and ensure that the unit will only run with the lid and the chute door closed. Then check that the direction of rotation of the shaft is **CLOCKWISE** when viewed from above.

The direction of rotation of single phase units is set at the factory, if it is not rotating in the correct direction contact IMC. To change the direction of rotation of three phase units, switch off the machine, isolate the supply and interchange any two phase wires.

OPERATION

MF Range Universal Peelers are particularly easy to use, and feature a safety specification that prevents the operator touching any moving parts during operation.

The operating procedure is as follows:

- 1 Fit the appropriate bottom plate, ensuring that it is properly located on the drive shaft.
- 2 Load the peeling chamber with the vegetables to be peeled.

WARNING - do not fill the chamber above the top of the cylinder:

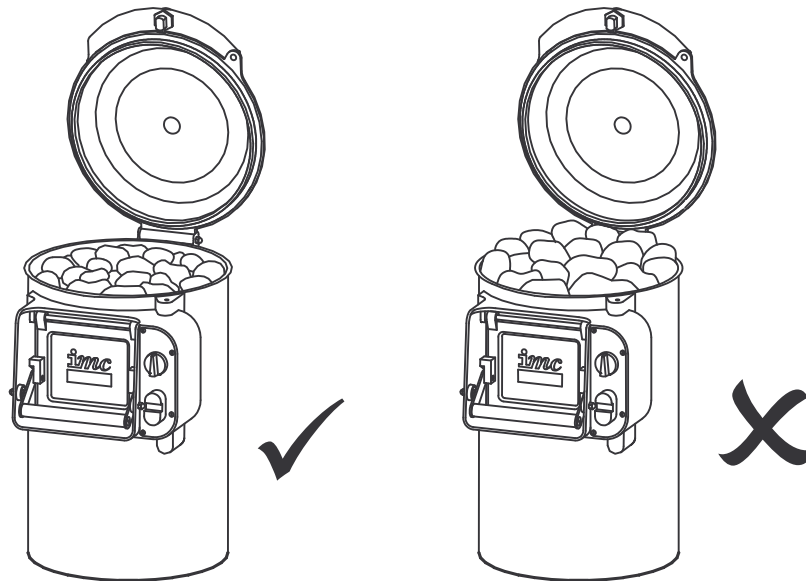

- 3 Close the lid and switch on the water at the tap to a steady flow. Experience will suggest how much water is required: if too little water is used waste will collect underneath the bottom plate; if too much water is used it will splash out of the opening in the lid.
- 4 Switch the timer on the control panel to the time desired - two minutes is normally more than adequate - and press the green start button. The machine is now operating.
- 5 On completion of the cycle, switch off the water supply, open the chute door and while keeping the door open, press the start button. This will discharge the potatoes only when the start button is depressed.



ON NO ACCOUNT put a hand or implement into the machine, or wedge the door open while discharging.

OPTIONAL PLATES

- 1 **Washing Plate** - used for washing new crop potatoes and carrots, or main crop potatoes that are to be cooked without peeling, for example jacket potatoes. Cannot be used with liner versions.
- 2 **Mussel Washing Plate** - this plate cleans all but the most stubborn dirt from mussels prior to cooking. Cannot be used with liner versions.
- 3 **Knife Peeling Plate** - used for achieving a smoother finish on, particularly, potatoes and carrots. A filter basket (or sink skip) must be used. Cannot be used with liner versions.
- 3 **Onion Peeling Plates** - for peeling onions and shallots. A filter basket (or sink skip) must be used. Cannot be used with liner versions.
- 4 **Salad Spinning Basket** - gently spins excess moisture from lettuce leaves after washing.

Plate order numbers

Extra plates can be purchased from your machine supplier or direct from IMC using the following part numbers

| Plate | MF5 | MF10 | MF15 |
|------------------------|---------|---------|---------|
| Standard Peeling Plate | S59/163 | S59/164 | S59/164 |
| Washing Plate | S59/172 | S59/173 | S59/173 |
| Mussel Washing Plate | S59/174 | S59/175 | S59/175 |
| Knife Peeling Plate | S59/167 | S59/168 | S59/168 |
| Onion Peeling plate | S59/165 | S59/166 | S59/166 |
| Salad Spinning Basket | S59/169 | S59/170 | S59/171 |

SAFETY

All MF-Range machines are fitted with a number of safety features to prevent operator injury.

No-volt release: If the electricity supply is interrupted the machine will not restart until the green start button is pressed again.

Lid interlock: If the lid is opened during operation the motor automatically cuts out and cannot be restarted until the lid is closed and the green start button has been pressed.

Door interlock: If the chute door is opened during operation the motor automatically cuts out and cannot be restarted until the chute door is closed and the green start button has been pressed. To discharge the door must be held open and the green button depressed ensuring two handed operation.

Door baffle: An inner door baffle prevents the operator reaching into the peeling chamber through the discharge door.

CLEANING

It is essential to clean the machine at least once a day, preferably at the end of each period of operation.

- 1 Switch off at the socket or isolator.
- 2 Open the peeler chamber lid.
- 3 Lift out the peeling plate.
- 4 Clean the peeling plate in a sink, dishwasher, potwash or by hosing with a spray.
- 5 Rinse the inside of the peeling chamber, door and lid with warm water, using a mild detergent if necessary. Do not forget to clean the area between the two doors.
- 6 Wipe the exterior of the machine with a damp cloth, again using a mild detergent if required.

DO NOT USE CLEANING MATERIALS CONTAINING ABRASIVES OR BLEACHES. DO NOT STEAM CLEAN

MAINTENANCE

Other than regular cleaning the MF-Range peelers require no maintenance by the end user. It is recommended that the unit is serviced by an IMC approved engineer at least once a year

Details of IMC Service Contracts are available on application.

DO'S AND DON'TS

- Do** Install on a level service.
- Do** Ensure power supply isolator is accessible with the peeler installed.
- Do** Clean the machine after use.
- Don't** Sit or stand on top of the peeler.
- Don't** Place hands inside unit while discharging.
- Don't** Use the unit outside.

ORDERING SPARE PARTS

In the event that spare parts or accessories need to be ordered, please always quote the SERIES AND SERIAL NUMBER of the machine. This is to be found on the rating plate located at the back of the machine near the supply cable. For installations outside the UK please contact your supplier.

For information on IMC spares and service support in the UK, please call the following numbers:

| | |
|--------------------------|-----------------------------------------|
| IMC Service Desk | 01923 718017 |
| IMC Spares Desk | 01923 718018 |
| IMC Spares & Service Fax | 01923 896256 |
| E-mail | service@imco.co.uk spares@imco.co.uk |

MATERIAL CONTENT

The MF-Range peelers contain the following materials

| | |
|---------------------|-----------------------------------------------------------------|
| Metals | Stainless steel, Mild steel (inc plated), Aluminium and copper. |
| Plastics and rubber | Polycarbonate, Nylon, Neoprene rubber. |
| Other | Aluminium oxide, electrical components. |