

Distributed BY

**JustCatering.Com Ltd**

10 Jessop Avenue, Norwood Green, Middlesex, UB2 5UY, UK

Tel +44 (0)8450034271 Mobile: 07929291670

E-mail: [sales@justcatering.com](mailto:sales@justcatering.com) Web: <http://www.justcatering.com>

# Food Waste Processing Stations



Reduce your rubbish



Cut your food waste disposal costs



Minimise your impact on the environment

**Food** Waste to Resource



## IMC's Food Waste Processing Stations



# Cut your food waste disposal costs by up to 80%



Reduce substantially the amount of rubbish you need to dispose of.



Improve your carbon footprint and reduce your impact on the environment.

### IMC Food Waste Processing Stations:-

- Reduce or even eliminate your food waste disposal costs
- Reduce the amount of waste requiring handling and storage.
- Free up other waste products for recycling (such as paper, cardboard, tins and plastics).
- Incur minimal operating cost.
- Consume very little water.
- Require minimal staff time to operate.
- Are simple and cheap to install.
- Are safe and easy to use.
- Are compact and take up limited space.
- Have a long life and need minimal maintenance.

What's more, the dewatered food waste is the perfect material for recycling into compost or converting into renewable energy. Combined with their low running costs and outstanding value, IMC Processing Stations are good for the environment!

# Award winning Food Waste Management Systems from IMC

IMC has won numerous Awards over the past few years for its commercial catering food waste management systems. These have been awarded by expert judging panels across a range of industries from catering and facilities to waste and environmental management.



Rushlight Waste Innovation Award 2010  
Rushlight Organic Waste Award 2010



## Case Studies

IMC Food Waste Management systems are in use across a broad range of Private and Public Sector commercial catering establishments from hotels, restaurants, shopping and entertainment centres to universities, schools, prisons and hospitals.



### Imperial Machine Company Limited

Unit 1 Abbey Road,  
Wrexham Industrial Estate  
Wrexham LL13 9RF United Kingdom

Tel: +44 (0)1978 661155  
Fax: +44 (0)1978 729990  
Email: sales@imco.co.uk  
Web: www.imco.co.uk



# IMC builds a Food Waste Processing Station to meet every requirement

Food waste comprises of up to 80% liquid and can be extremely costly to dispose of. IMC's Processing Stations use a Food Waste Disposer to grind down the waste into small particles and a Dewaterer to extract the solids allowing the grey water to dispense to drain whilst the solids are captured in a small lidded bin.

Choose from a wide range of Processing Stations that are tailored to both process your waste efficiently and effectively and fit in with your existing kitchen layout.

All Stations are built to the same high quality standards that you would expect of IMC.

## High specification as standard

Hopper Rim guides the waste into the Food Waste Disposer.

Splash-back prevents any water or food from escaping down the back of the unit. Alternative heights can be specified.

One set of controls operates both the Food Waste Disposer and the Dewaterer.

Water Flow Control enables the operator to adjust the amount of water being used.

"WastePro" Dewaterer fitted as standard and can be run for as much or as little time as is required to process your waste.

Food Waste Disposer and Dewaterer are supplied pre-plumbed and pre-wired for easy installation.

Height adjustable feet counter uneven floor surfaces.

"WastePro" Dewaterer can be positioned to the left or right hand side of the Station.

Optional Class A air-break.

Optional Magnetic Cutlery Savers help to prevent cutlery from entering the Food Waste Disposer.

Choice of Food Waste Disposer model, specified according to the amount and type of waste to be processed.

Wide choice of dimensions or can be built to order.

Optional front and side panels protect against damage to the equipment and improve the aesthetics of the Station.

## Wide choice of options

# IMC Food Waste Processing Stations are available in a wide range of sizes and formats

Processing Stations can also be specified to fit in with a pre-existing run of tabling and with or without a sink or sorting table. In addition each station is supplied with a Drain Kit to ensure the outlet plumbing for the Dewaterer is installed correctly.

IMC Processing Stations can be built to a size that fits your kitchen perfectly. The Stations featured below represent just a small selection of options available.

## Processing Station 1.0m

1.0m wide unit with FWD model 725 fitted to the right hand side.

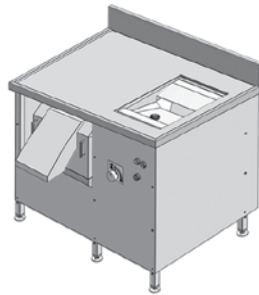

Shown with optional front and side panels



## Processing Station 1.5m

1.5m wide unit with FWD model 825 fitted to the right hand side.



Shown with optional front panel

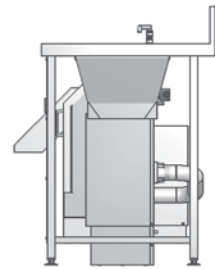

## Processing Station 1.5m

1.5m wide unit with FWD model 1204 fitted to the left hand side.

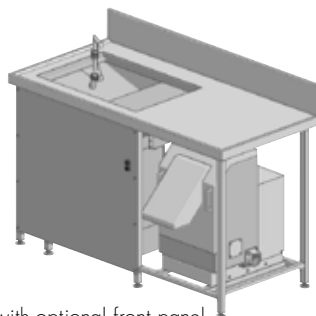

Shown with optional front panel

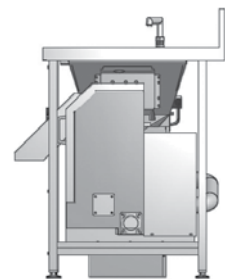

## Processing Station 2.2m

2.2m wide unit incorporating waste sorting table with FWD model 1604 fitted to the right hand side and 'WastePro' Dewaterer positioned outside.

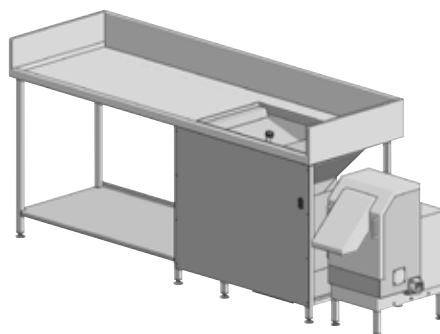

Shown with optional front panel and table side panels

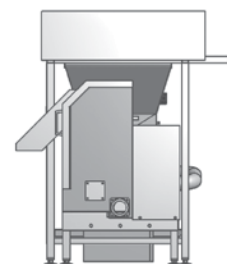

# IMC Processing Stations are able to process any food waste

From vegetable peelings and plate scrappings to large bones and fish skins, the correct Food Waste Disposer is specified to deal with the type, and the amount, of food waste that you have.

Below are just a few examples of the wide range of options available.

Model number	FWPS1000-725	FWPS1470-904	FWPS1470-825	FWPS2200-1204	FWPS2200-1604
Station width (m)	1.0	1.5	1.5	2.2	2.2
FWD model fitted	725	904	825	1204	1604
Covers per sitting	850	1,000	1,350	1,450	1,450
Waste per hour (kg)	400	500	600	700	700
Soft Waste	●	●	●	●	●
Medium waste	●	●	●	●	●
Tough waste			●	●	●
Model Kw	1.1	1.1	2.2	2.2	4
Motor HP	1.5	1.5	3	3	5.5

## Food Waste - what can be processed?

Processing Stations are designed to handle all kinds of food waste. By treating the food waste as it is produced, other waste items can be processed separately and, wherever possible, recycled.



**IMC Processing Stations use minimal water...**



IMC's Water Flow Control allows you to adjust the volume of water that the Food Waste Disposer consumes whilst processing the waste, thereby reducing water consumption and saving you money.

**...and are economical to run**



An IMC Food Waste Disposer requires less than 10 minutes to process 100kg of food waste using minimal electricity.