

JustCatering.Com

Distributed BY

JustCatering.Com Ltd

10 Jessop Avenue, Norwood Green, Middlesex, UB2 5UY, UK

Tel +44 (0)8450034271 Mobile: 07929291670

E-mail: sales@justcatering.com Web: <http://www.justcatering.com>

Cleaning, Rinsing and Polishing

Kitchen hygiene with power and performance

imc
fresh thinking

Pre-Rinse Spray Units

Our pre-rinse spray units help you improve the efficiency of dishwashers and levels of hygiene by allowing food scraps, sauces and juices to be rinsed from crockery or glassware quickly and simply. Features include lightweight, heat insulated spray heads, with rubber bumpers to protect crockery and extendable hoses for cleaning adjacent equipment.

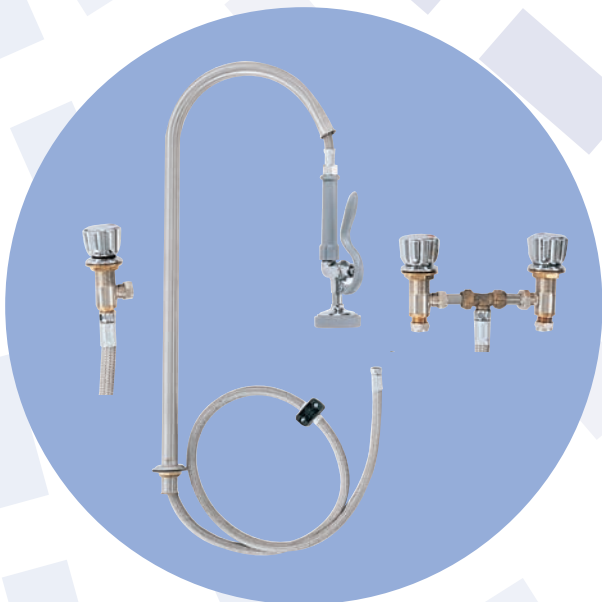

Reach of hose	1.5m (5ft)
Water pressure range	0.4 to 5 bar (4 to 50m head)
Water temperature	65°C (150°F) maximum
Features	Lightweight, heat insulated spray head Protective rubber bumper on spray head Stainless steel spirally wound covered hose Stainless steel vertical tube Wall bracket for vertical tube
Options	With water connection (PR1) With single tap (PR2) With mixer tap (PR3) Bracing stay for island locations

Spray Units

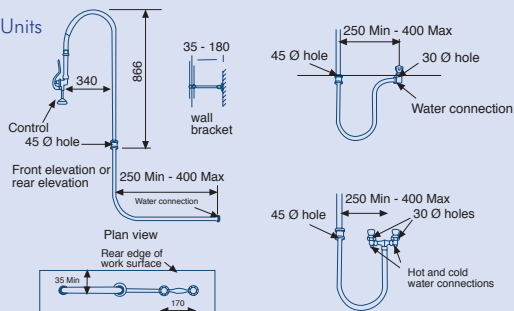

Reel Kleen

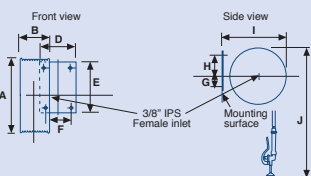

Model	A	B	D	E	F	G	H	I	J
RK15	290	65	92	172	62	71	71	313	560
RK35	336	80	177	253	127	70	133	384	640

Reel Kleen Hose Reels

Compact and space saving Reel Kleen hose reels can be wall, ceiling or floor mounted with hose lengths of 4.5 or 10m, allowing your staff to easily clean all parts of kitchen wash-up areas. Each unit is automatically retractable and features a tough, reinforced hose to ensure a long and trouble-free operating life.

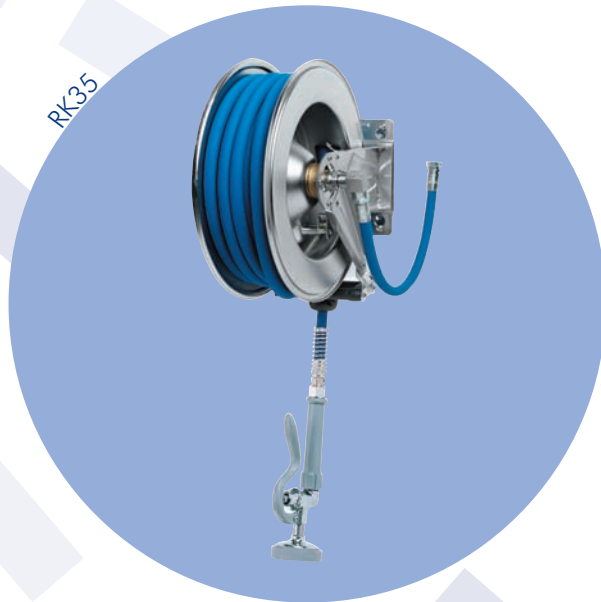

Reach of hose RK15	4.5m (15ft)
Reach of hose RK35	10m (35ft)
Water pressure range	2.1 to 13.8 bar (21 to 140m head)
Water temperature	82°C (180°F) maximum
Features	Reinforced rubber hose Re-coil system Built-in multi-bracket for wall, floor or ceiling mounting

Pot Boy

Pot Boy is a powerful and cost effective system for cleaning encrusted or stubborn deposits from pots, pans and other cookware. Pot Boy is easy and quick to use, and has low running costs. It can be mounted over sink units or supplied with a trolley for cleaning fixed catering equipment such as griddles, brat pans and ranges in-situ. Safety is assured through its unique hydraulic system: the brush head is driven by a fluid circuit which provides both electrical isolation and overload protection.

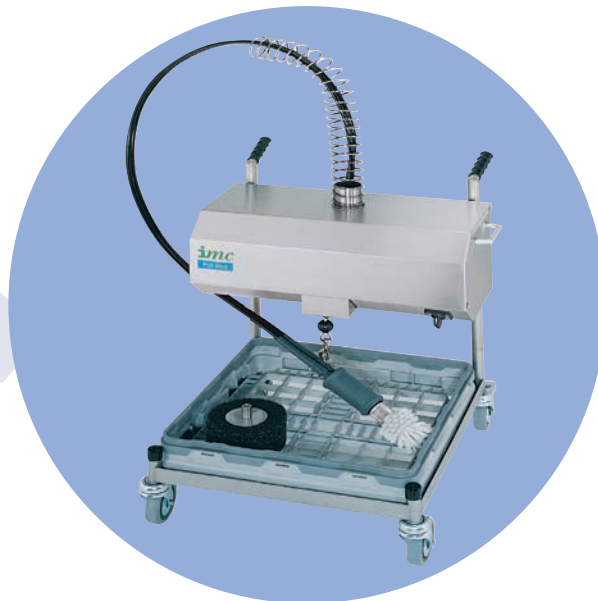
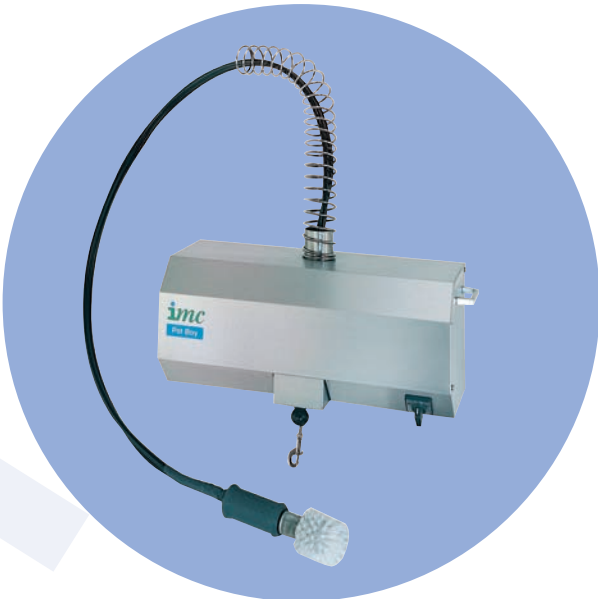

Reach of hose	1.5m (5ft)
Motor	0.37kW (0.5HP)
Fuse rating	1 phase (13A)
Head speed	360 rpm
Hydraulic fluid pressure	30 bar
Mounting height	1.15m above sink base
Features	Wall mounting plate Foot operated pneumatic switch Long lasting nylon brush head Magikut exterior scrubber
Options	Mobile trolley to clean fixed equipment
Spares	Long lasting nylon brush head Magikut exterior scourer (5 pads)

A4 Burnisher

The A4 Burnisher brings your solid silverware back to life, producing a bright sparkling finish and extending the life of cutlery and other genuine silver items. Quick, safe and simple to operate, the A4 Burnisher can hold up to 350 items of cutlery and can also be used for burnishing silver coffee pots, plates and even champagne buckets.



Capacity	Up to 350 pieces of cutlery Silver items up to 260mm diameter
Motor	0.25kW (0.33HP)
Fuse rating	1 phase (10A) or 3 phase (5A)
Features	70kg steel balls 10kg burnishing powder 1kg degreasant Teapot rod - hangs pot by handle to prevent damage Division plates - divides burnisher into sections Magnetic pick-up tool to collect steel balls
Spares	Burnishing powder Degreasant Steel balls

Pot Boy

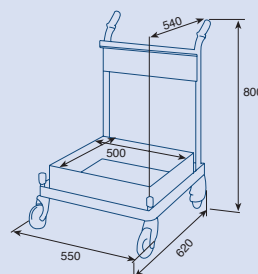
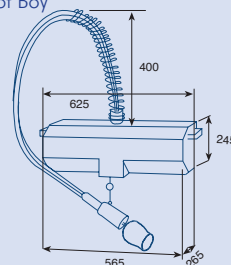

A4 Burnisher

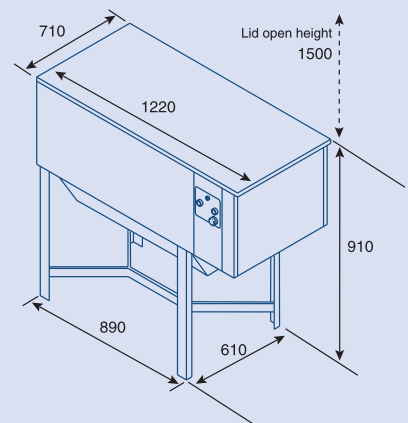

Distributed BY

JustCatering.Com Ltd

10 Jessop Avenue, Norwood Green, Middlesex, UB2 5UY, UK

Tel +44 (0)8450034271 Mobile: 07929291670

E-mail: sales@justcatering.com Web: <http://www.justcatering.com>

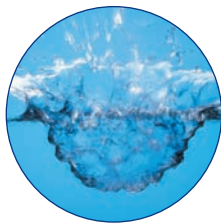

Also available is our range of compactors, food waste disposers and dewaterers. All are designed for use where food waste cannot be disposed of via mains drainage. Please contact us for further details.

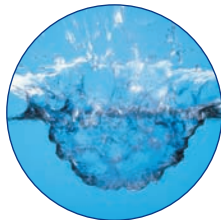

IMC was founded in 1906 and has since established itself as a leading manufacturer of catering and bar equipment, with a reputation for quality, innovation and unrivalled customer service.

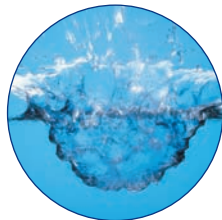

We have the resources, manufacturing expertise, knowledge and skills to provide you with complete waste management and catering solutions all of which is designed and manufactured to meet BS EN ISO9001:2000.

Distributed BY

JustCatering.Com Ltd

10 Jessop Avenue, Norwood Green, Middlesex, UB2 5UY, UK

Tel +44 (0)8450034271 Mobile: 07929291670

E-mail: sales@justcatering.com Web: <http://www.justcatering.com>

