

JustBars.Com

Distributed by JustCatering.Com Ltd

10 Jessop Avenue, Norwood Green, Middlesex, UB2 5UY, UK

Sales Tel & Fax: +44 (0)8450034271 Sales Direct Line: 07006342365

E-mail: sales@justbars.com www.justbars.com

BM Top Loading Bottle Coolers

Cooling innovation for bars

imc
fresh thinking

Display, performance, practicality



Designed for underbar use and to compliment our Bartender range of modular underbar systems, the BM range can be integrated perfectly into new or existing Bartender bar runs.



All models are available with unique sliding glass doors to allow contents to be seen without opening. Perfect at busy times when service and stocking are paramount. The reduced opening times for the glass door option help to reduce running costs.



The BM range utilises the latest compressor technology to ensure rapid cooling and constant temperatures whatever the situation.

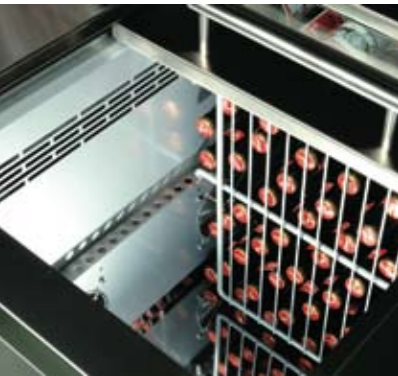

Conventional storage using optional dividers

Dimensions	H (mm)	W (mm)	D (mm)	Capacity (330ml bottles)
BM70 STD	875	700	560	140
BM70 BT	950	700	560	140
BM100 STD	875	1000	560	210
BM100 BT	950	1000	560	210
BM140 STD	875	1400	560	308
BM140 BT	950	1400	560	308

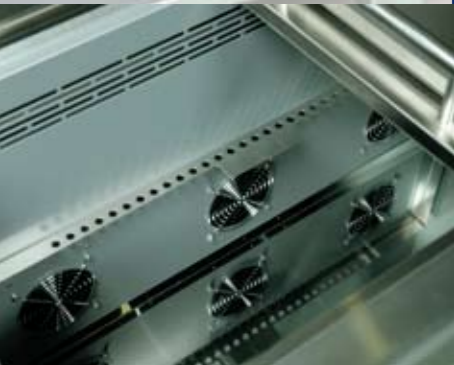

Rapid cooling times mean that bottled and canned drinks can be chilled and served faster, helping your staff manage customer demand especially at busy periods.



Available with standard front and no splashback the new BM range can be installed in any bar environment.

With a range of shelving and divider options the BM range allows bottles to be stored in the vertical position enabling rapid loading and serving while still maintaining the essential contact with the customer.





The BM range is also available with easy to use baskets, allowing quick and efficient restocking while maintaining greater stock control.



Available in 700mm, 1000mm and 1400mm wide versions, the high quality BM range is supplied in hygienic and extremely durable stainless steel. Ideal for any bar environment.



The Mistral Range

The stylish Mistral bottle coolers can be specified as part of a complete bar solution or individually as required.

For more information please contact IMC.



IMC was founded in 1906 and has since established itself as a leading manufacturer of commercial catering and bar equipment, with a reputation for quality, innovation and unrivalled customer service.



We have the resources, manufacturing expertise, knowledge and skills to provide you with the ultimate bar solutions and we offer complete peace of mind as all of our systems are designed and built to meet BS EN ISO9001: 2000

JustBars.Com

Distributed by JustCatering.Com Ltd
 10 Jessop Avenue, Norwood Green, Middlesex, UB2 5UY, UK
 Sales Tel & Fax: +44 (0)8450034271 Sales Direct Line: 07006342365
 E-mail: sales@justbars.com www.justbars.com

imc
 fresh thinking



Distributed by JustCatering.Com Ltd
10 Jessop Avenue, Norwood Green, Middlesex, UB2 5UY, UK
Sales Tel & Fax: +44 (0)8450034271 Sales Direct Line: 07006342365
E-mail: sales@justbars.com www.justbars.com

Technical Information BM Top Loading Bottle Coolers



August 2008

Overview

The BM range of stainless steel top loading bottle coolers are available in 3 width variations, 700mm, 1000mm and 1400mm with a stainless steel and painted grey mild steel interior. Each cooler comes complete with an innovative shelving system as standard, which allows easy access to the lower storage area.

Designed for underbar use, the BM range can be ordered with either a standard worktop, suitable for any bar environment; or with the optional Bartender® worktop, allowing perfect integration into new or existing bars that feature IMC's Bartender® range of modular stainless steel workstations.

All models feature forced air cooling for rapid and efficient pull down times, while a revolutionary frame design ensures a robust construction, long term reliability and low operating costs.

Product Conformity

BM top loading bottle coolers conform to the following directives:

- Machinery Directive 98/37/EC
- Low Voltage Directive 2006/95/EC
- Electromagnetic Compatibility Directive 2004/108/EC.

Every BM top loading bottle cooler is manufactured in accordance with the following transposed harmonised European Standards:

- EN ISO 12100-1 : 2003, Safety of machinery; basic concepts, general principles for design – Part 1: Basic terminology, methodology.
- EN ISO 12100-2 : 2003, Safety of machinery; basic concepts, general principles for design – Part 2: Technical principles and specifications.
- EN 60204-1 : 2006, Safety of machinery; Electrical equipment of machines - Part 1: General requirements
- EN 61000-6-1 : 2001 Electromagnetic compatibility (EMC).
Generic standards Immunity for residential, commercial and light-industrial environments
- EN 61000-6-3 : 2001 Electromagnetic compatibility (EMC) - Generic standard.
Emission standard for residential, commercial and light-industrial environments

Product Details

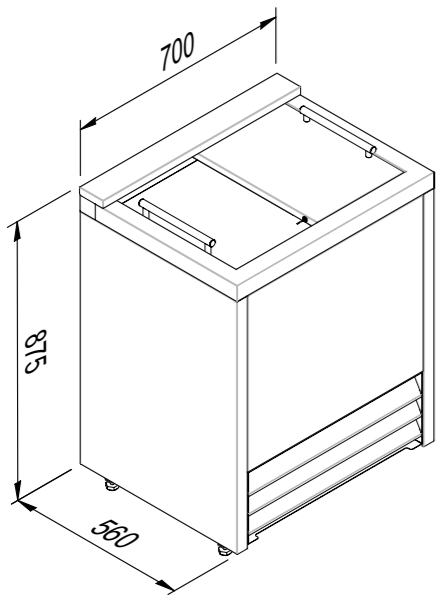

Standard Features	Optional Features
<ul style="list-style-type: none"> • Forced air cooling • Parallel sliding doors • Bottle shelves • Bottle opener and catcher • Door locks • Vertical bottle stocking • Electronic controller • Condensate evaporation 	<ul style="list-style-type: none"> • Bartender front and splashback • Glazed doors • Lighting • Bottle baskets • Bottle dividers

Standard Worktop	BM70 STD	
External Dimensions (h x w x d)	875mm x 700mm x 560mm	
Packing Dimensions (h x w x d)	1100mm x 740mm x 600mm	
Weight (Kg) - Unpacked	70	
Weight (Kg) - Packed	75	
Storage Capacity (330 ml Bottles)	140	
Internal Operating Temp (°C)	+ 4 (±2)	
Ambient Temp (°C)	upto + 32	
Voltage (Volts)	230	
Frequency (Hz)	50	
Phase	Single	
Current Draw (Amps)	1.5	
Refrigerant Type	R134 A	
Product Codes	Part No	
Solid Door	F73/070 SS	
Glazed Door	F73/071 SS	
Options	Qty Required	Part No
Bottle Basket	4	A12/089
Divider Pack	1	S73/010
Internal Light Pack	1	VS321

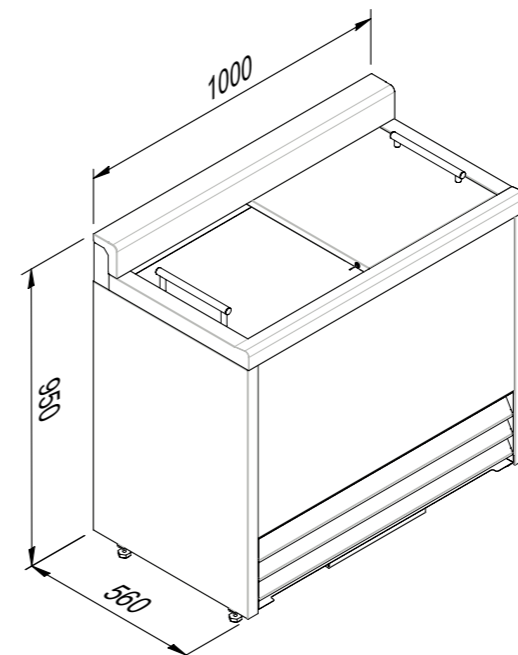
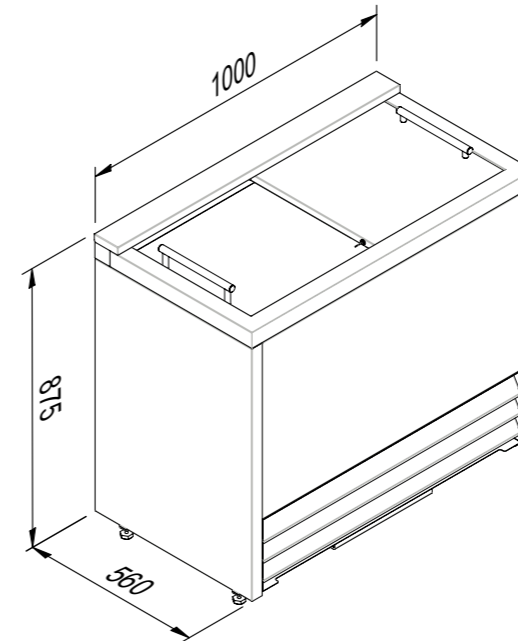
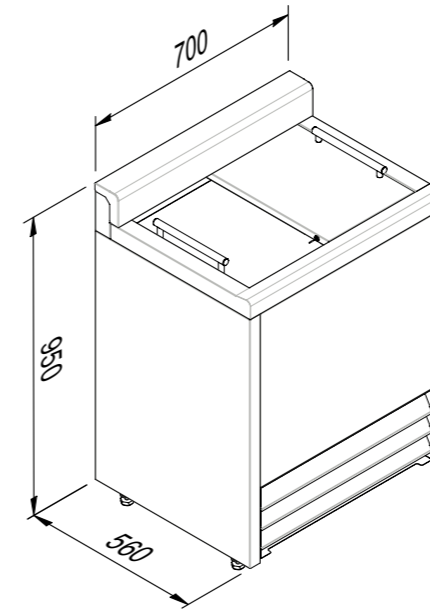

Bartender Worktop	BM70 BT	
External Dimensions (h x w x d)	950mm x 700mm x 560mm	
Packing Dimensions (h x w x d)	1100mm x 740mm x 600mm	
Weight (Kg) - Unpacked	70	
Weight (Kg) - Packed	75	
Storage Capacity (330 ml Bottles)	140	
Internal Operating Temp (°C)	+ 4 (±2)	
Ambient Temp (°C)	upto + 32	
Voltage (Volts)	230	
Frequency (Hz)	50	
Phase	Single	
Current Draw (Amps)	1.5	
Refrigerant Type	R134 A	
Product Codes	Part No	
Solid Door	F73/072 SS	
Glazed Door	F73/073 SS	
Options	Qty Required	Part No
Bottle Basket	4	A12/089
Divider Pack	1	S73/010
Internal Light Pack	1	VS321

Standard Worktop	BM100 STD	
External Dimensions (h x w x d)	875mm x 1000mm x 560mm	
Packing Dimensions (h x w x d)	1100mm x 1040mm x 600mm	
Weight (Kg) - Unpacked	88.5	
Weight (Kg) - Packed	94	
Storage Capacity (330 ml Bottles)	210	
Internal Operating Temp (°C)	+ 4 (±2)	
Ambient Temp (°C)	upto + 32	
Voltage (Volts)	230	
Frequency (Hz)	50	
Phase	Single	
Current Draw (Amps)	1.6	
Refrigerant Type	R134 A	
Product Codes	Part No	
Solid Door	F73/100	
Glazed Door	F73/101	
Options	Qty Required	Part No
Bottle Basket	6	A12/089
Divider Pack	1	S73/110
Internal Light Pack	1	VS321

Bartender Worktop	BM100 BT	
External Dimensions (h x w x d)	950mm x 1000mm x 560mm	
Packing Dimensions (h x w x d)	1100mm x 1040mm x 600mm	
Weight (Kg) - Unpacked	88.5	
Weight (Kg) - Packed	94	
Storage Capacity (330 ml Bottles)	210	
Internal Operating Temp (°C)	+ 4 (±2)	
Ambient Temp (°C)	upto + 32	
Voltage (Volts)	230	
Frequency (Hz)	50	
Phase	Single	
Current Draw (Amps)	1.6	
Refrigerant Type	R134 A	
Product Codes	Part No	
Solid Door	F73/102	
Glazed Door	F73/103	
Options	Qty Required	Part No
Bottle Basket	6	A12/089
Divider Pack	1	S73/110
Internal Light Pack	1	VS321

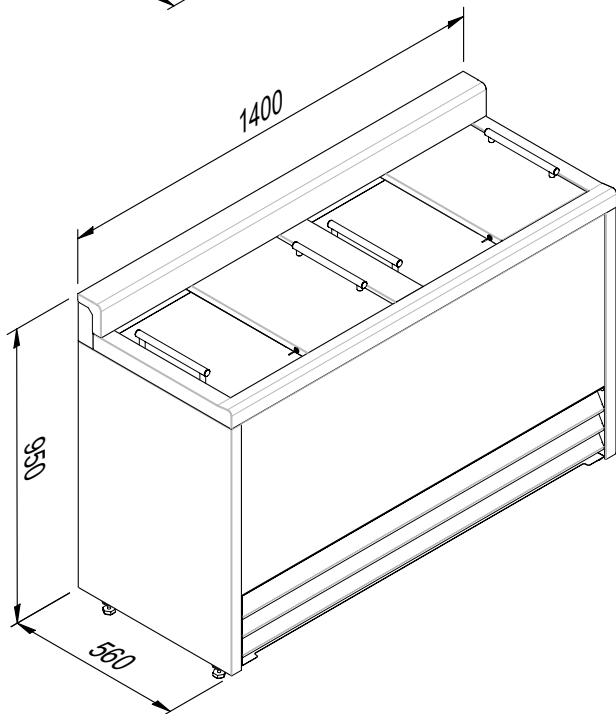
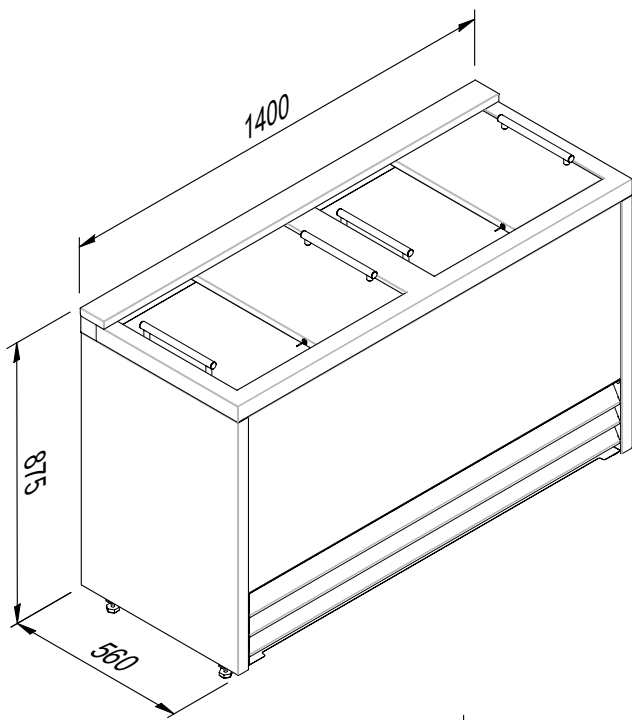

Standard Worktop	BM140 STD	
External Dimensions (h x w x d)	875mm x 1400mm x 560mm	
Packing Dimensions (h x w x d)	1100mm x 1440mm x 600mm	
Weight (Kg) - Unpacked	113	
Weight (Kg) - Packed	120	
Storage Capacity (330 ml Bottles)	308	
Internal Operating Temp (°C)	+ 4 (±2)	
Ambient Temp (°C)	upto + 32	
Voltage (Volts)	230	
Frequency (Hz)	50	
Phase	Single	
Current Draw (Amps)	1.75	
Refrigerant Type	R134 A	
Product Codes		
	Part No	
Solid Door	F73/140	
Glazed Door	F73/141	
Options		Part No
Bottle Basket	10	A12/089
Divider Pack	1	S73/210
Internal Light Pack	1	VS322

Bartender Worktop	BM140 BT	
External Dimensions (h x w x d)	950mm x 1400mm x 560mm	
Packing Dimensions (h x w x d)	1100mm x 1440mm x 600mm	
Weight (Kg) - Unpacked	113	
Weight (Kg) - Packed	120	
Storage Capacity (330 ml Bottles)	308	
Internal Operating Temp (°C)	+ 4 (±2)	
Ambient Temp (°C)	upto + 32	
Voltage (Volts)	230	
Frequency (Hz)	50	
Phase	Single	
Current Draw (Amps)	1.75	
Refrigerant Type	R134 A	
Product Codes		
	Part No	
Solid Door	F73/142	
Glazed Door	F73/143	
Options		Part No
Bottle Basket	10	A12/089
Divider Pack	1	S73/210
Internal Light Pack	1	VS322

Notes

JustBars.Com

Distributed by JustCatering.Com Ltd
 10 Jessop Avenue, Norwood Green, Middlesex, UB2 5UY, UK
 Sales Tel & Fax: +44 (0)8450034271 Sales Direct Line: 07006342365
 E-mail: sales@justbars.com www.justbars.com

imc
 fresh thinking